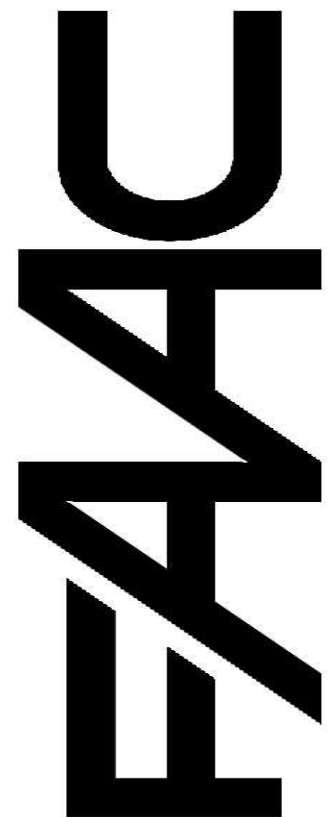

THE 390 24V OPERATOR AND 425 D CONTROL PANEL: INSTALLATION MANUAL

July, 2006
390 24v Operator And
425 D Control Panel
Installation Manual

CONTENTS

Important Safety Information	2
Technical Data	4
Unpacking the Operator	5
The 390 24V Operator General Characteristics	6
Installation Instructions	6
Prepare the Gate	6
Manual Release Mechanism	6
Install the Operator	7
Mounting Dimensions	7
Mounting the Base Plate	7
390 Limit Switch Instructions	10
Exploded View, 390 24V Operator	12
390 24V Operator Parts List	13
The 425 D Control Panel Installation Instructions	
The 425 D Control Panel General Description	14
Installing the 425 D Control Panel	14
Connect the Main Power Supply	14
Connect the Operator to the Control Panel	14
Connect Accessory Devices	15
Set Operating Modes	16
Setting the DIP Switches	17
Obstacle Recognition	17
Programming	19
Display Descriptions	20
Programming the Motor Run Time	20
Fuse Ratings	20
Maintenance	21
Safety in Gate Design	21
Troubleshooting	22
Limited Warranty	24

The logo for FAAC International, Inc. consists of the letters 'FAAC' in a large, bold, black, sans-serif font. The letters are stacked vertically, with 'F' at the bottom, 'A' in the middle, and 'A' and 'C' at the top. The 'F' and the bottom 'A' are connected at the base.

FAAC International, Inc.
303 Lexington Avenue
Cheyenne, WY 82007
www.faacusa.com

IMPORTANT SAFETY INFORMATION

Both the installer and the owner and/or operator of this system need to read and understand this installation manual and the safety instructions supplied with other components of the gate system. This information should be retained by the owner and/or operator of the gate.

WARNING! To reduce the risk of injury or death

1. **READ AND FOLLOW ALL INSTRUCTIONS.**
2. Never let children operate or play with gate controls. Keep the remote control away from children.
3. Always keep people and objects away from the gate. **NO ONE SHOULD CROSS THE PATH OF THE MOVING GATE.**
4. Test the gate operator monthly. The gate **MUST** reverse on contact with a rigid object or stop when an object activates the non-contact sensors. After adjusting the force or the limit of travel, retest the gate operator. Failure to adjust and retest the gate operator properly can increase the risk of injury or death.
5. Use the emergency release only when the gate is not moving.
6. **KEEP GATES PROPERLY MAINTAINED.** Read the owner's manual. Have a qualified service person make repairs to gate hardware.
7. The entrance is for vehicles only. Pedestrians must use separate entrance.
8. **SAVE THESE INSTRUCTIONS.**

When installing the photo-beams supplied with this unit two things need to be considered.

1. Care should be exercised to reduce the risk of nuisance tripping, such as when a vehicle, trips the sensor while the gate is in motion.
2. One or more photobeams shall be located where the risk of entrapment exists, such as the perimeter reachable by the moving gate leaf.

GATE DESIGN

1. A gate is a potential traffic hazard, so it is important that you locate the gate far enough away from the road to eliminate the potential of traffic getting backed up. This distance is affected by the

size of the gate, how often it is used, and how fast the gate operates.

2. The operator you choose to install on your gate must be designed for the type and size of your gate and for the frequency with which you use the operator.
3. Your gate must be properly installed and must work freely in both directions before the automatic operator is installed.
4. An automatic operator should be installed on the inside of the property/fence line. Do not install the operator on the public side of the property/fence line.
5. Pedestrians should not use a vehicular gate system. Prevent such inappropriate use by installing separate gates for pedestrians.
6. Exposed, reachable pinch points on a gate are potentially hazardous and must be eliminated or guarded.
7. Outward swinging gates with automatic operators should not open into a public area.
8. The operating controls for an automatic gate must be secured to prevent the unauthorized use of those controls.
9. The controls for an automatic gate should be located far enough from the gate so that a user cannot accidentally touch the gate when operating the controls.
10. An automatic gate operator should not be installed on a gate if people can reach or extend their arms or legs through the gate. Such gates should be guarded or screened to prevent such access.

INSTALLATION

1. If you have any question about the safety of the gate operating system, do not install this operator. Consult the operator manufacturer.
2. The condition of the gate structure itself directly affects the reliability and safety of the gate operator.
3. Only qualified personnel should install this equipment. Failure to meet this requirement could cause severe injury and/or death, for which the manufacturer cannot be held responsible.
4. The installer must provide a main power switch that meets all applicable safety regulations.
5. Clearly indicate on the gate with the 2 warning signs that are included (visible from either side of the gate).

6. It is extremely unsafe to compensate for a damaged gate by increasing hydraulic pressure.
7. Devices such as reversing edges and photobeams must be installed to provide better protection for personal property and pedestrians. Install reversing devices that are appropriate to the gate design and gate application.
8. Before applying electrical power, be sure that the voltage requirements of the equipment correspond to your supply voltage. Refer to the label on your operator system.

USE

1. Use this equipment only in the capacity for which it was designed. Any use other than that stated should be considered improper and therefore dangerous.
2. When using any electrical equipment, observe some fundamental rules:
 - Do not touch the equipment with damp or humid hands or feet.

- Do not install or operate the equipment with bare feet.
 - Do not allow small children or incapable persons to use the equipment.
3. If a gate system component malfunctions, turn off the main power before making any attempt to repair it.
 4. Do not attempt to impede the movement of the gate. You may injure yourself as a result.
 5. This equipment may reach high temperatures during operation; therefore, use caution when touching the external housing of the operator.
 6. Learn to use the manual release mechanism according to the procedures found in this installation manual.
 7. Before carrying out any cleaning or maintenance operations, disconnect the equipment from the electrical supply.
 8. To guarantee the efficiency of this equipment, the manufacturer recommends that qualified personnel periodically check and maintain the equipment.

U.L. CLASS AND FAAC OPERATOR

Model	Duty Cycle	Typical Use
Class I: Residential Vehicular Gate Operator		
390	750	<ul style="list-style-type: none"> • Home use • Small apartment building, for example, up to 4 units in a building, with limited public access
422	760	
415	400	
620	640	
885	402	
Limited duty		
Class II: Commercial/General Access Vehicular Gate Operator		
400	640	<ul style="list-style-type: none"> • Apartment buildings • Very public access
620	885	
Continuous duty		
Class III: Industrial/Limited Access Vehicular Gate Operator		
400	640	<ul style="list-style-type: none"> • No public access
620	885	
Continuous duty		
Class IV: Restricted Access Vehicular Gate Operator		
620	640	<ul style="list-style-type: none"> • Prison rated security
885		
Continuous duty		

TECHNICAL DATA

THE 390 OPERATOR

Parameter	Measure
Voltage required, VDC	24 Vdc
Duty type	Residential
Maximum duty cycle	100%
Maximum leaf length, ft (m)	14 (3)
Maximum leaf swing, deg	120

Parameter	Measure
Motor RPM	960
Operating Ambient Temp. Deg F (Deg C)	-4 thru +131 (-20 thru +55)
Operator dimensions, l' w' h, in. (mm)	See figure 1
Operator weight, lb (kg)	25.5 (11.5)
Current draw, Amp	2
Maximum amperage draw for accessories, mA	.630mA

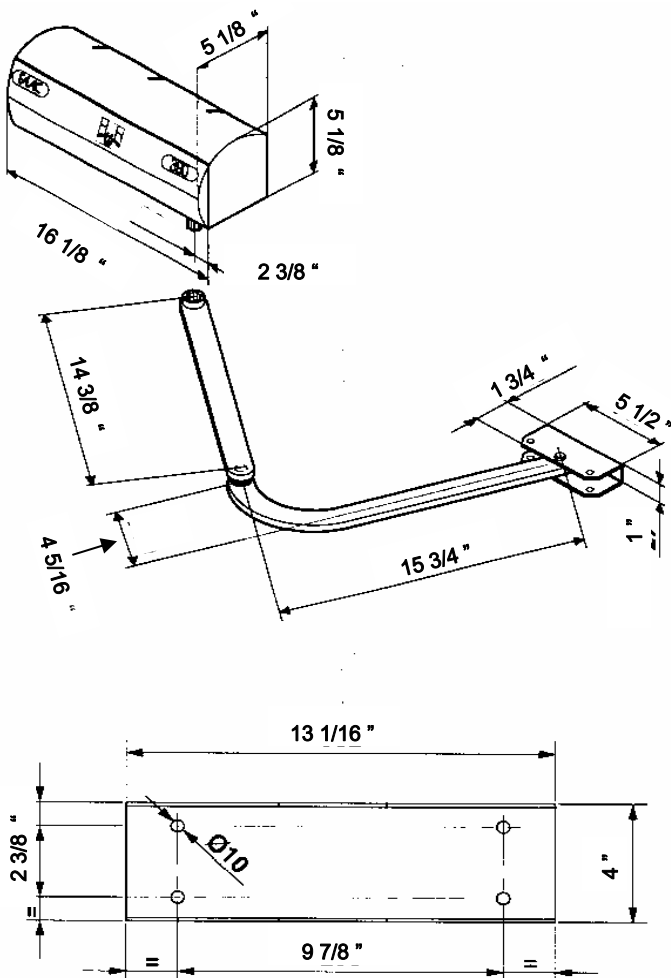

Figure 1. 390 Operator Dimensions

UNPACKING THE OPERATOR

When you receive your 390 24 V Operator, complete the following steps.

Inspect the shipping box for physical damage such as a torn carton. Then inspect the operator after you remove it from the box. Notify the carrier immediately if you note any damage because the carrier must witness the damage before you can file a claim.

As you unpack the box, insure that all the parts listed below are included (See Figure 2).

Control panel enclosure with control panel and transformer.

The 390 Operator is supplied with the following parts

① 390 Operator Cover

② Operator securing base-plate

③ 390 Motor Assembly

④ Splined Shaft

⑤ Straight Arm (Articulated Arm)

⑥ Curved Lever (Articulated Arm)

⑦ Front Mounting Bracket

⑧ Manual Release

⑨ Manual Release Key

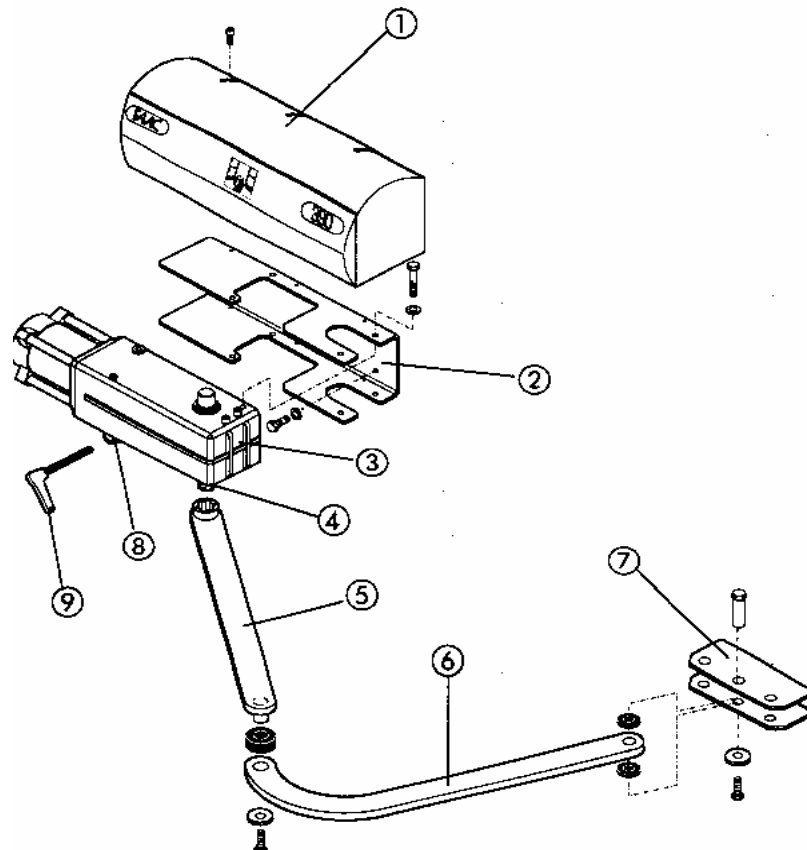

Figure 2. 390 Operator included parts.

THE 390 24v OPERATOR

GENERAL CHARACTERISTICS

The FAAC 390 24v Operator is an automatic gate operator for a residential swinging gate leaf that is ideal for large columns.

The self-contained 390 24v Operator consists of a irreversible electromechanical motor and articulated arm.

The locking the 390 24v Operator provides in the fully opened and fully closed positions is a service device rather than a security device. Additional, external locks are recommended under the following conditions:

- * It is a solid-faced gate.
- * The length of the gate leaf is 6 ft (2 m) or longer.
- * The installation requires tight security.
- * The site is subject to vandalism.
- * The site is subject to strong or very gusty wind

In two-operator gate installations, both (master/slave) operators are wired to one control panel.

The electronic control panel is a microprocessor-based controller that accepts a wide range of product accessories and reversing devices, thus allowing for flexible gate system design.

Also for the protection and proper operation of the 390 24v Operator, each operator has available optional limit switches.

Built-in security and anti-crushing measures of the 390 24v Operator include built in reverse on contact and a torque adjustment that controls the force transmitted to the gate leaf through the 390 24v Operator.

The Manual Release mechanism is a key-operated device that disengages (or engages) the gears in 390 24v Operator. When the drive is disengaged, you can open and close the gate leaf by hand. Such manual operation of the gate is necessary during installation and useful during prolonged power failures.

The torque of the 390 24v Operator is set during Basic Programming of the 425 D Control Panel. (see page 19 for Basic Programming).

Reversing devices (such as inductive loops and photocells) should be installed to provide non-contact reversing operation.

WARNING: To insure that the installation meets the UL 325 Standards. A set of photo beam (Part Number 785163) must be installed anywhere that an entrapment with the gate leaf(s) could happen.

The 425 D also has a built in battery back-up system that can be used with the addition of 2 12V 7ah batteries. The batteries must be wired in series to provide 24VDC to the control panel during power outages.

During prolonged power outages the manual release may be used if needed.

INSTALLATION INSTRUCTIONS

Installing the 390 24v Operator involves preparing the gate, installing the operator(s), installing the control panel, programming control panel, and connecting other operational controls.

Note: The following installation instructions assume you are fully capable of installing an electromechanical operator on a gate. This manual does not instruct you in designing a gate, installing a gate (whether on masonry, wood, or metal posts), or basic electrical wiring. The installation tasks discussed in this manual are tasks particular to the 390 24v Operator.

PREPARE THE GATE

Before you install the 390 24v Operator, you need to prepare the gate itself for the operator. Be sure to do the following:

Make sure that the gate structure is solidly built. Add reinforcing crosspieces if necessary to the gate leaves. Make sure that the gate moves smoothly on its hinges without excessive friction by swinging it opened and closed by hand. If necessary, lubricate all the gate's moving parts.

Positive stops are needed with the 390 24v Operator unless you have purchased the optional Limit Switch Kit (FAAC Part Number 390682)

MANUAL RELEASE MECHANISM

To manual release the 390 24v Operator perform the following steps as shown in figure 3.

If the gate has to be operated manually in the event of a power outage, use the manual release mechanism as follows:

Insert the supplied Allen wrench (manual release key) and turn it by a half turn until it stops in the direction shown in figure 3, depending on type of installation.

Now the 390 24v Operator is manual released. You can move the gate freely.

RESTORING OPERATOR TO NORMAL OPERATION

To avoid an involuntary pulse from activating the gate during the maneuver, before re-locking the operator switch off power to the system.

Fit the supplied Allen wrench (manual release key) and turn it by a half turn until it stops, in the direction shown in figure 3, depending on type of installation.

INSTALLING THE OPERATOR

Once you have prepared the gate, you are ready to proceed with the installation of the operator.

To ensure safety and an efficient automation, make sure the following requirements are met:

- * The gate structure must be suitable for automation. In particular, make sure it is sufficiently sturdy and rigid, and that its dimensions are in line with those indicated in the technical specifications.
- * Make sure that the leaves move properly without any binding during their entire travel.
- * Check if hinges are in good condition.

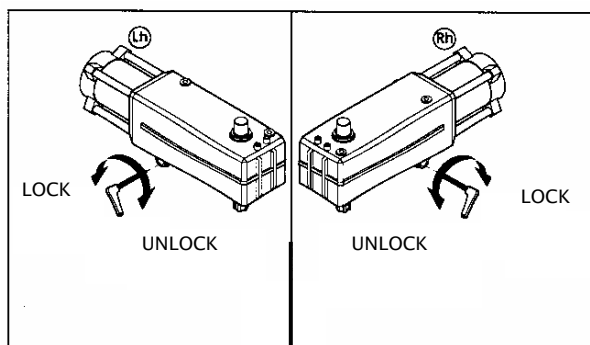

Figure 3. Manual Release

- * Make sure the positive stops are in place. (unless you are using the optional Limit Switch Kit)

MOUNTING DIMENSIONS

Install the operator by using the following tables. See figures 5 & 6. The outward dimensions are ideal for an "overhead" outward swinging garage/carriage door.

MOUNTING THE BASE PLATE

The 390 24v Operator Base Plate can be used for either Right Hand (DX) or Left Hand (SX) installations.

Note: The splined shaft must always face down.

- * Secure the base plate to the column and check to see if it is level. Figure 4.
- * Fit the 390 Operator into the base plate and secure it with the 2 screws, nuts and lock washers. Figure 7
- * Assemble the articulated arm and front mounting bracket as shown in figure 8.
- * Attach the articulated arm to the 390 Operator with the supplied screw and washer. Figure 9.
- * With the operator released, established the position of the front mounting bracket to the gate by checking dimensions C in figure 5 & 6. The bracket can be welded or bolted to the gate leaf. See figure 10
- * Attach the operator cover to the operator.
- * Attach the power cord to the control panel.

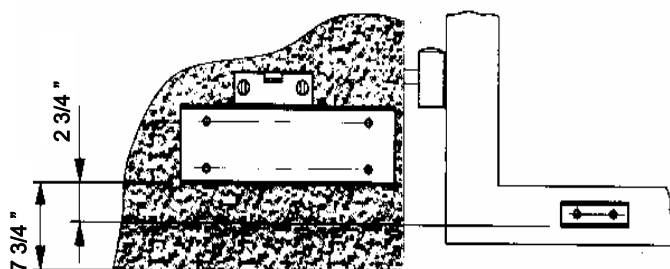

Figure 4. Operator Position

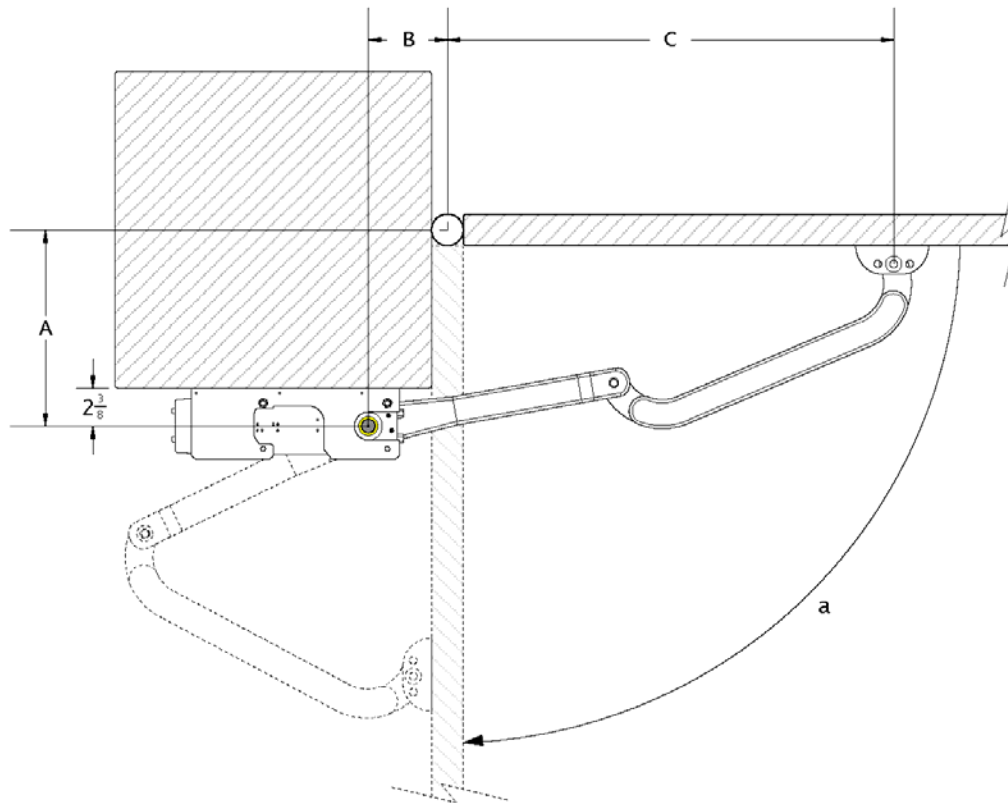

Figure 5. Dimensions for Inward Opening
Typical gate applications

A	B	C (max)	a°
2¼" - 4¼"	4¼" - 5¼"	28¾"	90°
4¼" - 6¼"	4¼" - 5¼"	28¼"	90°
6¼" - 8¼"	4¼" - 5¼"	28"	90°
8¼" - 10¼"	4¼" - 5¼"	27½"	90°
10¼" - 12¼"	4¼" - 5¼"	27"	90°
12¼" - 14¼"	4¼" - 5¼"	26¼"	90°
2¼" - 4¼"	7½" - 8¼"	25½"	120°
4¼" - 6¼"	9" - 10"	23½"	120°
6¼" - 8¼"	11½" - 12¼"	21¼"	120°
8¼" - 10¼"	12¼" - 13"	20"	120°

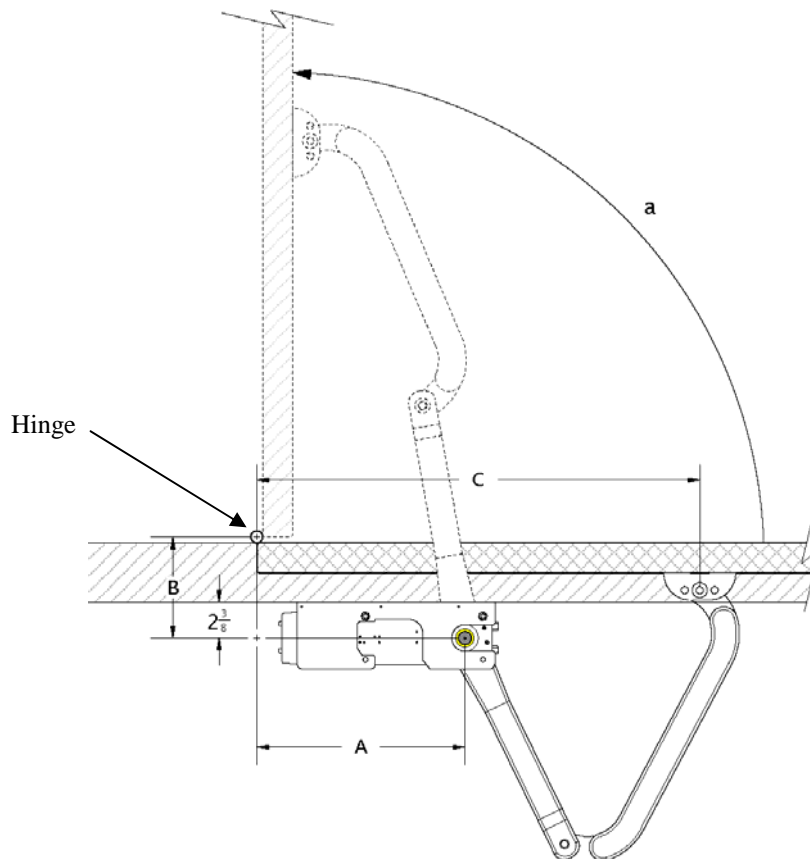

Figure 6. Typical “overhead” outward swing mounting dimensions for garage/carriage door applications.

A	B	C (max)	a°
2¼" - 4¼"	4¼" - 5¼"	28¾"	90°
4¼" - 6¼"	4¼" - 5¼"	28¾"	90°
6¼" - 8¼"	4¼" - 5¼"	28"	90°
8¼" - 10¼"	4¼" - 5¼"	27½"	90°
10¼" - 12¼"	4¼" - 5¼"	27"	90°
12¼" - 14¼"	4¼" - 5¼"	26¼"	90°
2¼" - 4¼"	7½" - 8¼"	25½"	120°
4¼" - 6¼"	9" - 10"	23½"	120°
6¼" - 8¼"	11½" - 12¼"	21¼"	120°
8¼" - 10¼"	12¼" - 13"	20"	120°

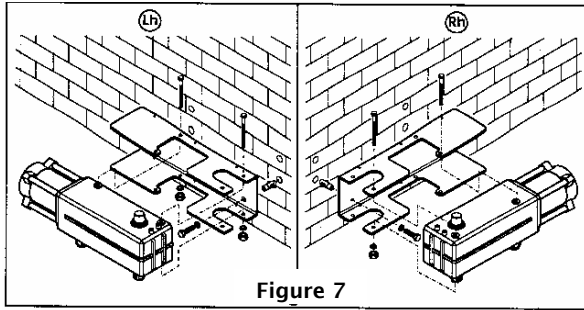

Figure 7 shows how to attach the operator to the base plate.

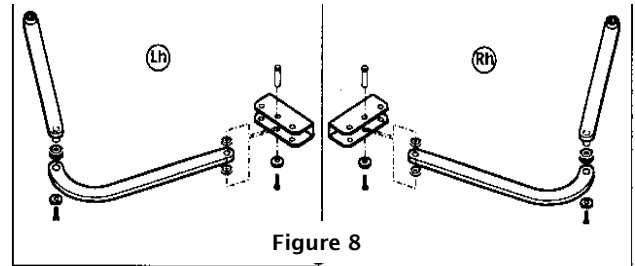

Figure 8 shows how to assemble the articulated arm and front bracket.

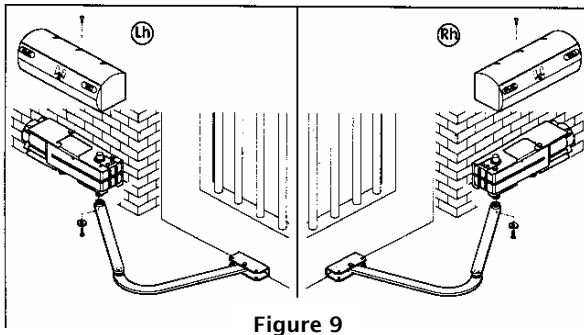

Figure 9 shows how to attach the articulated arm and operator cover to the operator.

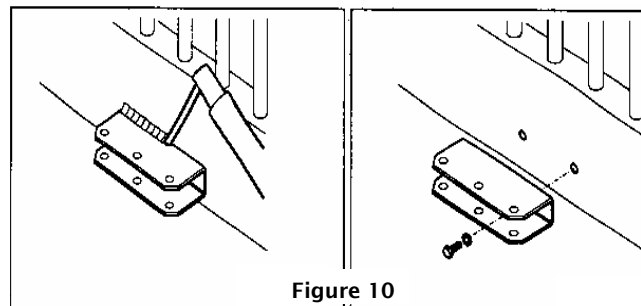
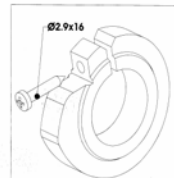
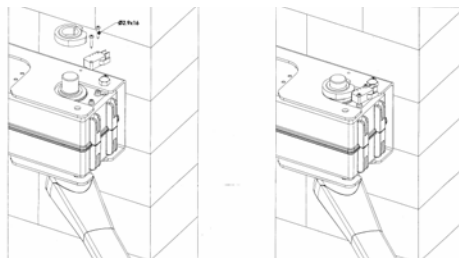

Figure 10 shows how to attach the front mounting bracket to the gate leaf(s).

390 Limit Switch Instructions



When Using 1 Limit Switch (Open or Closed Stop)



When Using 2 Limit Switches (Open and Closed Stops)

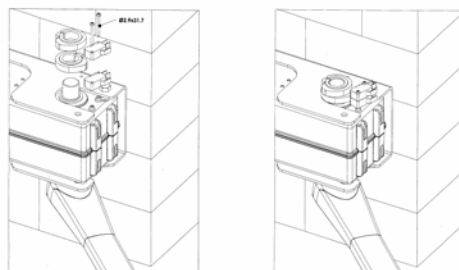
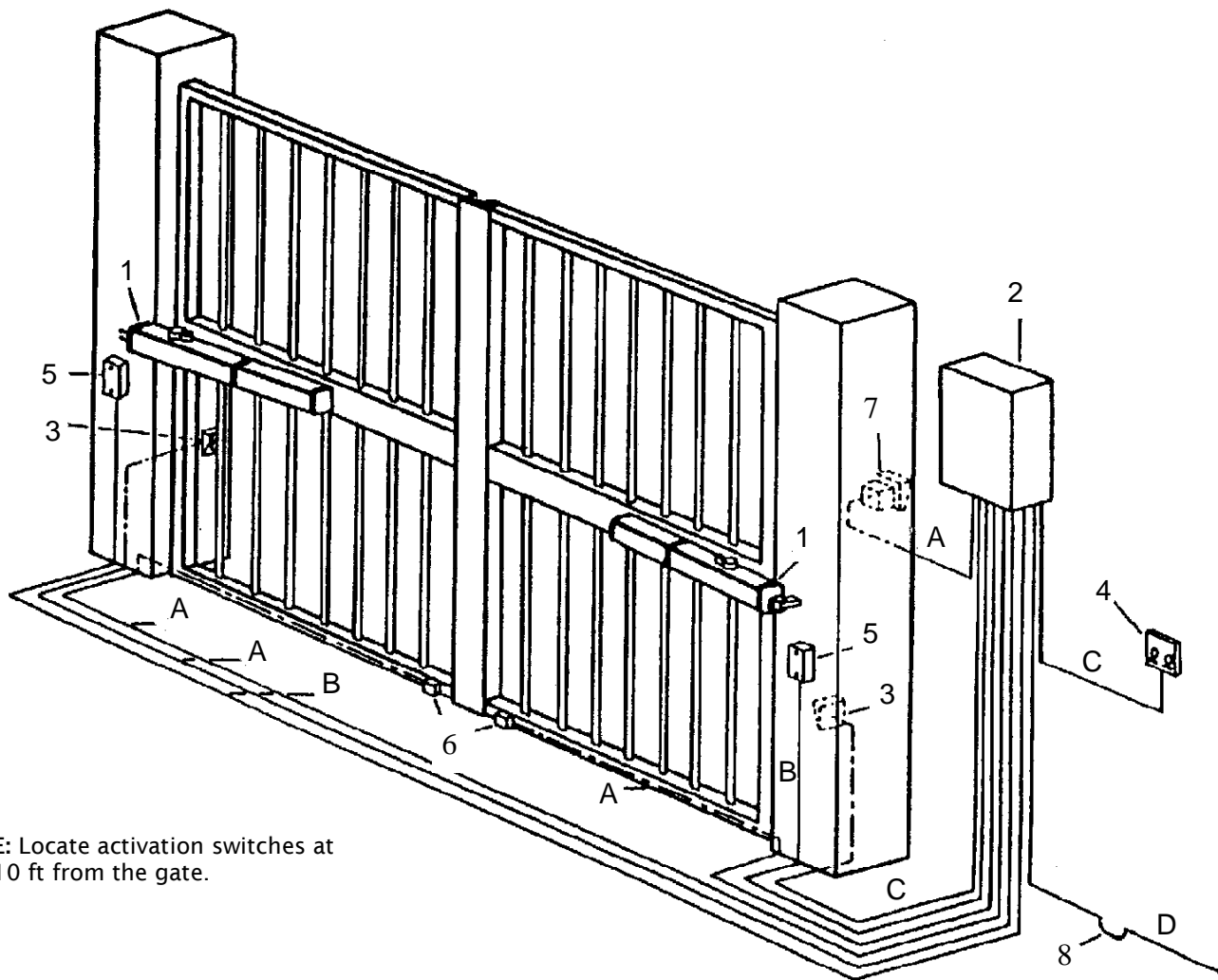

Figure 1. The layout of a sample gate system



NOTE: Locate activation switches at least 10 ft from the gate.

1	Operator	Wire Gauges for Given Voltage	
		110 VAC primary / 24 VAC 100 VA secondary	
2	Control Panel/Enclosure		
3	Photocell	A 2 × 18 AWG	A 2 × 18 AWG
4	Power Switch	B 4 × 14 AWG	B 4 × 14 AWG
5	FAAC 5 Wire Cable for Master/Slave Connection and Junction Box	C 5 × 18 AWG	C 5 × 18 AWG
6	Gate stops	provided by built in limit switch	
7	FAAC Key Activated Switch (T10)	A 2 × 18 AWG	A 2 × 18 AWG
8	Wiring to main circuit breaker	D 2 × 12 AWG	

The 390 24v Operator

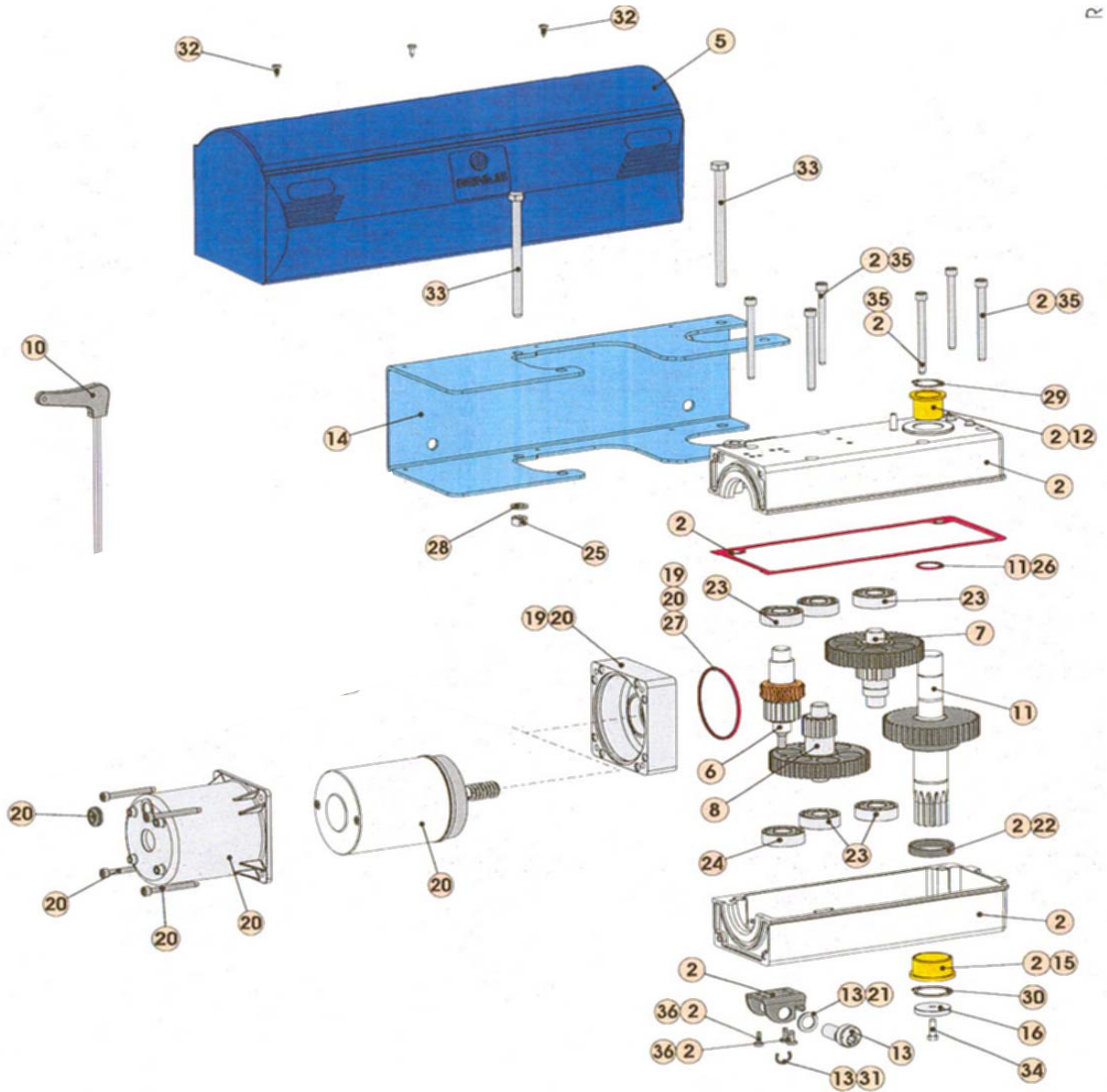

Parts List

390 24v Operator

POS	PART NO.	DESCRIPTION	QTY
2	N/A	Operator body	1
5	727292	Protective Cover	1
6	N/A	Manual Release Assembly (Inner)	1
7	N/A	Gear (Upper)	1
8	N/A	Gear (Lower)	1
10	713001	Key (Manual Release Lever)	1
11	718189	Gear (Main Drive Shaft)	1
12	N/A	Bushing Brass (Upper)	1
13	N/A	Manual Release (Outer)	1
14	722471	Mounting Frame	1
15	N/A	Bushing Brass (Bottom)	1
16	N/A	Fender Washer	1
17	N/A	Motor 24VDC	1
20	N/A	Motor Housing 24VDC	1
21	N/A	Snap Ring	1
22	N/A	Seal (Lower)	1
23	6202	Bearing (Sealed)	4
24	6206	Bearing (Sealed)	2
25	N/A	Nut (8mm x 1.25mm x 6.5mm)	1
26	N/A	Spacer	1
27	N/A	O-Ring (2.62mm x 61.60mm)	1
28	N/A	Washer (8mm x 2mm)	1
29	N/A	Snap Ring	1
30	N/A	Snap Ring	1
31	N/A	"C" Clip	1
32	N/A	Screw Self Tapping (3.5mm x 9.5mm)	3
33	N/A	Bolt (8mm x 110mm)	2
34	N/A	Bolt (5mm x 16mm)	3
35	N/A	Screw Cap (6mm x 70mm)	3
36	N/A	Screw (4mm x 10mm)	3

THE 425 D CONTROL PANEL

GENERAL DESCRIPTION

The FAAC 425 D control panel is used to operate the following models.

Swing gate operators:

415	412
390	770

The 425 D programming controls the following:

Operating logic: A, EP, logics available.

Pause time between opening and closing: Done during the motor programming time.

Opening/Closing time: Self Learning. (During the programming stage)

Leaf delay on closing: adjustable from 1.5 to 10 seconds.

Leaf delay on opening: 1.5

The 425 D control panel should be installed in an enclosure that is conveniently located as close as possible to the gate operator. All electrical connections from the control panel to the operator must be made in a weatherproof junction box.

The 425 D control panel requires the 100VA transformer (included) 115vac primary and 24vac secondary. The power supply should be protected by a 15 amp dedicated circuit breaker (not provided).

The installer is responsible for providing the main power breaker switch, and for making sure that the entire gate system meets all applicable electrical codes. The installer should refer to the installation manual for a given operator for more information.

NOTE: An installation is U.L. compliant only when you install the FAAC operators according to the UL325 standards.

INSTALLING THE 425 D CONTROL PANEL

Installing the control panel consists of the following general steps:

- * Connecting the main power to the control panel
- * Connecting the activating device
- * Connecting the operator to the control panel

- * Checking the direction of the motor's rotation
- * Connecting other devices to the control panel
- * Set operating modes

CONNECT THE MAIN POWER SUPPLY

WARNING! Turn the main power off before you make any electrical connections or before programming.

The main power can be provided in a variety of different ways.

- 1) Bring a 115VAC line into the enclosure and wire to the terminals provided, and plug the transformer into the outlet provided inside the enclosure.
- 2) Plug the transformer into any 115VAC outlet and bring the low voltage (24VAC) wires into the enclosure wiring them directly to the control panel as described below. Be sure to use the appropriate size wire for longer runs.

CONNECT THE OPERATOR(S) TO THE CONTROL PANEL

WARNING! Turn the main power off before you make any electrical connections.

USING A JUNCTION BOX

If an operator is more than 2 ft away from the control panel, you must use a junction box for connection. Use a U. L. Listed cord grip where the operator cord enters the junction box.

Note: If you have a one-leaf gate design, the operator **must** be connected to Motor 1 (terminals APM1 and CHM1) in the CN2 Terminal Block

To wire up motor 1, connect the blue wire to terminal APM1(on the CN2 terminal strip), the brown wire to CHM1..

Note: If you want to delay the closing of one gate leaf in a two-leaf gate design, be sure to connect its operator to Motor 1.

In order to wire motor 2 in a bi-parting system, connect the blue wire to terminal APM2 (on the CN2 terminal strip), the brown wire to CHM2.

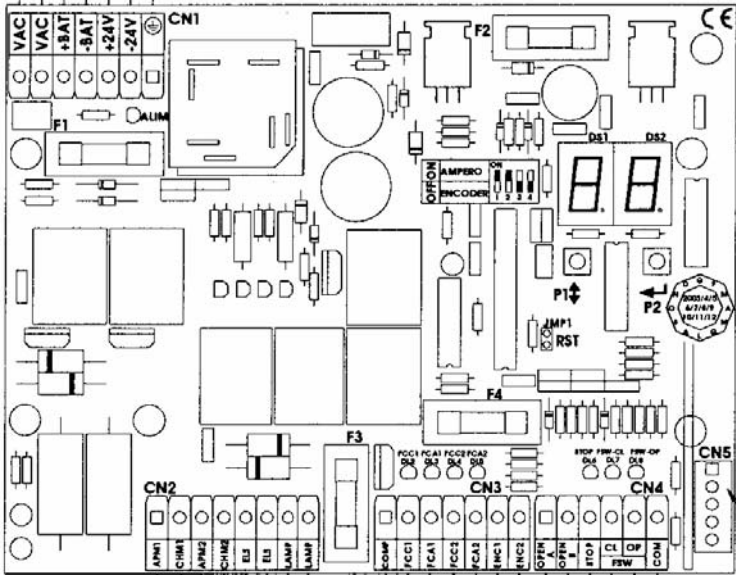

Figure 1. The 425 D Control Panel

- CN1 terminal block for main power supply, battery connections and accessory power
- CN2 terminal block for connecting the operator(s), lock, and lamp
- CN3 limit switch connections
- CN4 terminal block for low-voltage accessories input
- CN5 quick connector port for the FAAC plug in radio receiver.
- P1 Programming Push Button
- P2 Programming Push Button

FUSE RATINGS	
F1 Main Power	10A
F2 Accessories/Charging Circuit	1.6A
F3 Lamp	.800mA
F4 Electric Lock	3.15A

CONNECT OTHER DEVICES

WARNING! Turn the main power off before you make any electrical connections.

POWER SUPPLY FOR ACCESSORIES: You can access a 24 VDC output for supplying power to accessories through terminals +24V and -24V on terminal block CN1. In most cases, this source can be used to power 24 VDC accessories.

NOTE: The 425 D control panel allows a maximum accessory load of 630mA.

REVERSING DEVICES: Reversing devices include photocells, inductive loops, and so forth. All of the reversing devices should have contacts of the normally closed (N.C.) type. Where you connect a device depends on whether you want the device to operate during opening or during closing.

NOTE: UL **does not** recognize the FAAC system with loop detectors or safety edges. FAAC photobeams must be used to comply with UL 325.

To wire photobeams, refer to page 19 (see FSWOP for opening photobeams, and FSWCL for closing photobeams). Photobeams must be connected as shown. See also page 19 for the wiring of inductive loops. If using more than one reversing device, they must be wired in series.

NOTE: A shadow/intermittent loop cannot be wired to for use when using the 425 D control panel.

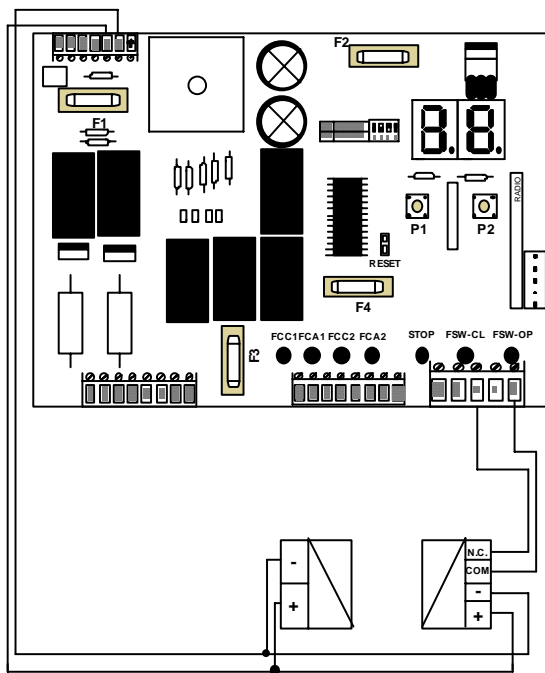

Figure 2. The terminal strip wiring of the 425 D with photobeams

THE 425 D CONTROL PANEL INSTALLATION INSTRUCTIONS

ACTIVATING DEVICES AND RADIO RECEIVER: The activating devices and radio receiver for your gate must have normally open (N.O.) contacts. Connect such devices to terminals OPEN A and COM.

NOTE: The FAAC radio receiver plugs into the 5 prongs labeled CN5 (Quick connect port).

Page 19 shows how to connect a three or four wire receiver.

FAAC PLUG IN RADIO RECIEVER: If you are installing the FAAC Receiver use the quick-fit connector CN5.

NOTE: If your using both a receiver and decoder, hard wire the decoder and plug in the receiver.

OPEN/HOLD OPEN DEVICE: To open and hold open the gate, simply maintain a contact across terminals OPEN A and COM. ("A" Mode only)

STOP BUTTON: The stop button you install must have normally closed (N.C.) contacts. Multiple stop buttons must be wired in series. Connect your stop device between terminals STOP and COM.

NOTE: The 425 D will not operate the motors without a closed circuit between STOP & COM.

The LED Indicators: The nine light emitting diodes (LEDs) on the control panel can be used to check for the proper function of the devices attached to the panel. The LED lights are on whenever the contacts are closed across each of the respective terminals.

LED	On	Off
DL1	Power On	Power Off
DL7 FSW CL	Closing Safeties Normal	Closing Safeties Triggered
DL8 FSW OP	Opening Safeties Normal	Opening Safeties Triggered
DL3 STOP	Stop Device Normal	Stop Signal Given
DL2,DL3 DL4,DL5 Limits	Limit Switches Normal	Limit Switches Triggered

OP_A and OP_B (Partial Opening) should illuminate only when an activating signal is sent for 2 and 1 gate leaves, respectively. STOP should be illuminated except when the stop button is pressed. FSWOP and FSWCL should be illuminated except when the reversing devices, for opening and closing, respectively, are triggered. Use the LEDs and the next table to determine if the accessory devices you have installed are operating properly.

Electric Locks: An electric lock can be wired to the 425 D in terminals ELS and ELS (24Vdc pulsed provided). If a reversing stroke is needed to allow the electric lock to release, this must be done in programming.

See page 19 for the connections for a magnetic locking device.

WARNING LIGHT: Connect a warning light to terminals labeled lamp in the CN2 terminal block. The terminals provide an output voltage of 24 VDC, maximum power 15 Watts. This output voltage will power most 24 VDC warning lights.

NOTE: The behavior of the warning light is as follows. During programming the light will flash every 1/2 second during opening and every 1 1/2 seconds during closing. If you are in automatic mode (A), upon reaching the open position, the output will remain on for 5 seconds to inform you that the gate will close automatically. It will also flash for up to 10 seconds if the gate is open and a safety is triggered.

The output can also be set as a courtesy light that stays illuminated for 90 seconds. See the programming section (G0 and G1) for further details

SET OTHER OPERATING CONTROLS

WARNING! Turn the main power off before you make any electrical connections.

You need to program the control panel for your gate's operation. The 425 D Control Panel has on board programming that controls a wide range of functions.

OPERATING LOGICS

NOTE: The 425 D Control Panel provides inputs for opening reversing devices and closing reversing devices. FAAC strongly recommends the use of reversing devices, such as photocells or other non-contact sensors.

- **A (automatic):** The gate opens on command and automatically closes after a pause phase. A second command while opening is ignored; a second command during the pause phase interrupts the pause time; a second command

during closing reopens the gate. A maintained open command will hold the gate open.

- **EP (semi-automatic, step by step):** This mode requires a command to open and a command to close. A second command during opening or closing causes the gate to stop. A third command then reverses the previous motion of the gate.

The two programming push buttons allow the programming of the force, logic settings, etc

WARNING! Turn the main power off before you make any electrical connections.

PAUSE TIME: The pause time between opening and closing is set during the motor run time programming section.

LEAF DELAY: You may choose to delay one leaf on closing for overlapping gate leaves. Be sure the operator on the leaf for delayed closing is connected to Motor 1.

The opening leaf-delay time of 1.5 seconds cannot be adjusted.

The closing leaf-delay time is adjustable from 1.5 to 10 seconds.

NOTE: If the opening/closing time is set at less than the leaf delay time, the delayed leaf closes at the end of the closing time.

SETTING THE DIP SWITCHES

Set the dip switches as follows:

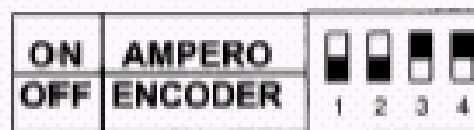

OBSTACLE RECOGNITION

In the event that two obstacles are sensed in succession, the motor(s) will stop. At this point the control panel will require an activation signal which will cause the motor(s) to run open and then close at slow speed to "reprogram" the location of the open and closed limit switches.

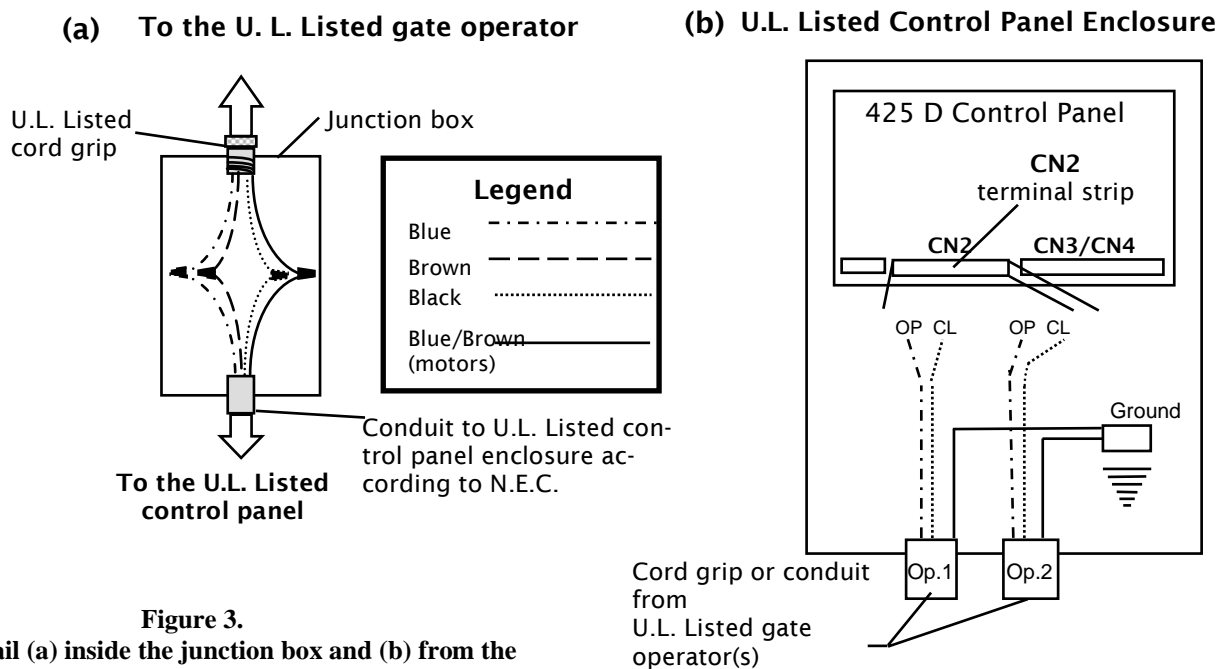
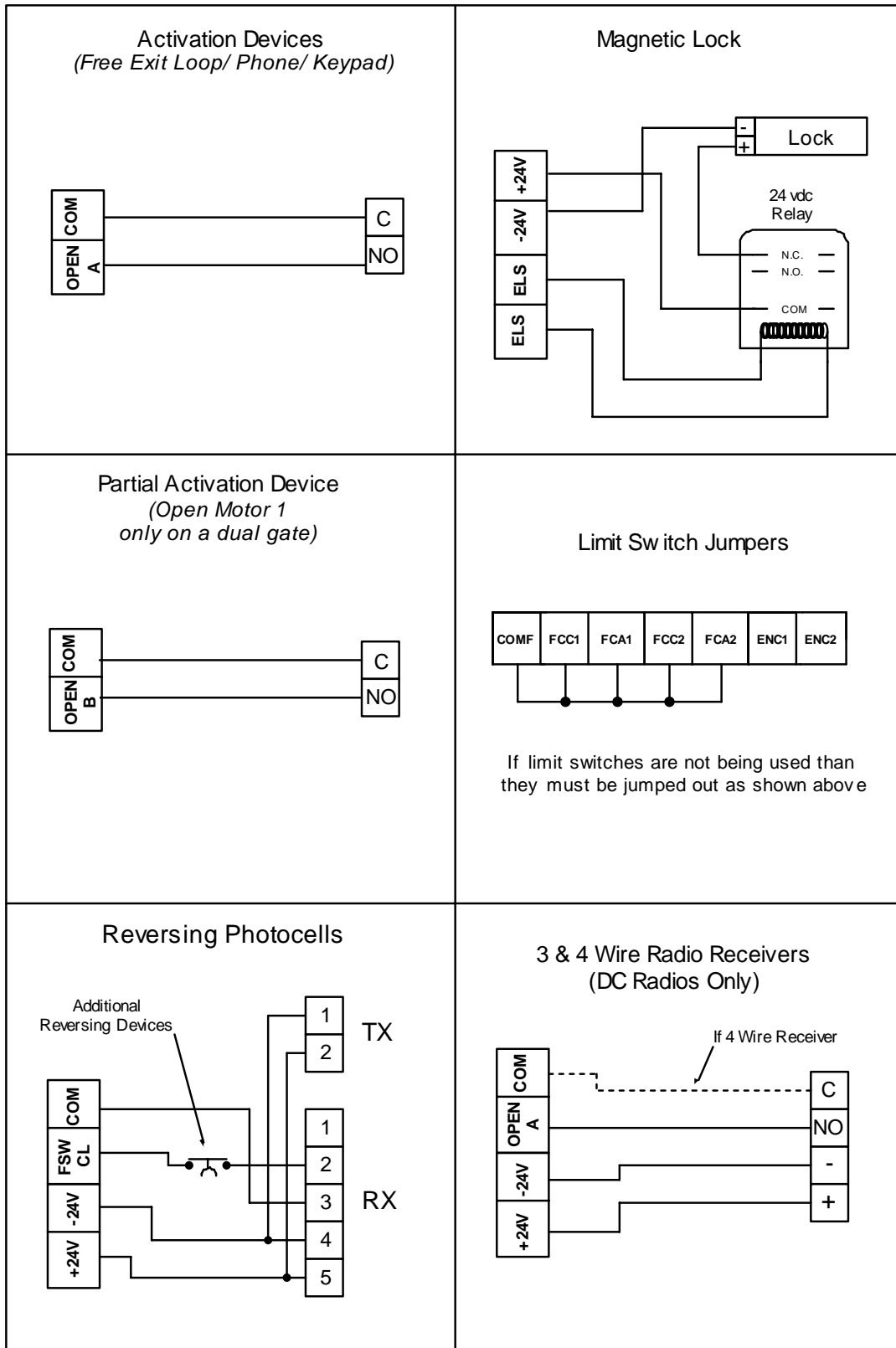

Figure 3.
 Wiring detail (a) inside the junction box and (b) from the junction box or operator to the high-voltage terminal strip on the 425 D control panel



NO = Normally Open, NC = Normally Closed, C = Common, TX = Transmitter, RX = Receiver

Figure 4. Common Accessories wired to 425 D Control Panel

PROGRAMMING

WARNING! Turn off the main power before you make any electrical connections or set any switches inside the control panel box.

To program the automated system, the "Programming Mode" must be accessed.

The 425D has two push buttons labeled P1 and P2 that are used to program how the control panel operates and responds to inputs.

1. The display should show "— —".
2. Press and hold the P2 button for 5 seconds until the display shows the first parameter.
3. To change the parameter values use the P1 button.
4. Use the P2 button to move from parameter to parameter.
5. If no buttons are pushed for 60 seconds then the board will automatically exit programming.
6. Continuing all the way through the program to the last parameter will also exit the program.

Use the following table to program the parameters required for your installation.

PROGRAM BUTTONS	
Left	Right
P1	P2

DISPLAY	DESCRIPTION
FORCE SETTING (Force Applied to the Gate)	
A1	Minimum force, maximum sensitivity
A2	Medium low force, maximum sensitivity
A3	Medium high force, minimum sensitivity
A4	Maximum force, minimum sensitivity

DISPLAY	DESCRIPTION
LEAF DELAY	
B1	1.5 seconds
B2	3 seconds
B3	6 seconds
B4	10 seconds
LOGIC SETTING	
C0	EP
C1	A
ACTIVATION COMMAND	
D0	Open/Close/Open
D1	Open/Stop/Close/Stop
SECURITY MODE	
E0	Only useful in EP Logic
E1	Only useful in A Logic
REVERSING STROKE (useful with electric locks)	
F0	Disabled
F1	Enabled
COURTESY LIGHT/WARNING LIGHT	
G0	Flashing Light
G1	Courtesy Light (Light stays lit solid for 90 seconds)
DECELERATION PERCENTAGE SETTING	
H0	20% of opening run time
H1	10% of opening run time
DECELERATION SPEED (SLOW DOWN SPEED)	
I0	High
I1	Low
LIMIT SWITCHES (WITH/WITHOUT)	
L0	Not using limit switches
L1	Using limit switches
NUMBER OF MOTORS	
M1	One operator connected
M2	Two operators connected

DISPLAY DESCRIPTIONS

The following table shows the descriptions of the display during a normal operating procedure

Value Shows	Descriptions
— — —	Gate Closed and at Rest
OP	Gate is Opening (Open in "E" Mode)
tc	Timer to Close (Pause Time)
CL	Gate is Closing

FUSE RATINGS

Fuse	Protects
F1 = 10Amp 250V	Main Power
F2 = 1.6Amp 250V	Accessories/Charging Circuit
F3 = .800mAmp 250V	Flashing Light
F4 = 3.15Amp 250V	Electric Lock Output

PROGRAMMING THE MOTOR RUN TIME

NOTE: The operators will run at slow speed during the motor run time programming phase.

The 425D features a self learning function for programming the motor run time, pause time, and deceleration of the 390 24V Operator(s). Follow the procedure below to complete this function.

1. Manually release the 390 operator(s), move the gate(s) to the halfway position, and reengage the operator(s). See figure 3, page 5.
2. Turn the power on. Ensure that the power led (DL1) is on.
3. Press and hold the P2 button until the display shows its first value. (Example A1,A2,A3, Or A4)
4. Give the panel an open activation with any normally open device wired to the OPEN A and COM terminals or the FAAC plug in radio receiver. Motor 2 should close first, followed by motor 1.
5. If either gate moves toward the open direction, touch the two RESET (JMP1) pins, (see figure 2) with a small screwdriver or piece of wire. This will cause the gate to stop.
6. Turn the power off to the control panel and reverse the motor wires to the operator that ran open. Turn the power back on to the control panel and start again at step 1.
7. Once the motor(s) is (are) running toward the closed position, it (they) should do so until the closed limit switch is reached.
8. After 2 seconds, motor 1 should begin to run open, after and after another 2 seconds motor 2 should run open. It (they) continue until the open limit switch(s) is (are) reached.
9. When the gate(s) reach the open position, the control panel begins to count the pause time. Once the desired pause time (timer to close) has elapsed, give the panel an open activation. Motor 2 should begin to close, followed by motor 1. The gate(s) will run until the closed limit switch(s) is (are) reached.
10. Programming is now complete. The display will show "— —".

MAINTENANCE

THE 390 24V OPERATOR

The FAAC 390 24V Operator requires no maintenance. Periodically inspect the operator, however, to ensure continued proper operation.

THE 425 D CONTROL PANEL

Keep the Control Panel free from spider webs, insects, etc. Otherwise the Control Panel requires no maintenance.

SAFETY IN GATE DESIGN

- A gate is a potential traffic hazard, so it is important that you locate the gate far enough away from the road to eliminate the potential of traffic getting backed up. This distance is affected by the size of the gate, how often it is used, and how fast the gate operates.
- The operator you choose to install on your gate must be designed for the type and size of your gate and for the frequency with which you use the operator.
- Your gate must be properly installed and must work freely in both directions *before* the automatic operator is installed.
- An automatic operator should be installed on the inside of the property/fence line. Do not install the operator on the public side of the property/fence line.
- Outward swinging gates with automatic operators should not open into a public area.
- Pedestrians should not use a vehicular gate system. Prevent such inappropriate use by installing separate gates for pedestrians.
- The operating controls for an automatic gate must be secured to prevent the unauthorized use of those controls.
- The controls for an automatic gate should be located far enough from the gate so that a user cannot accidentally touch the gate when operating the controls.
- Exposed, reachable pinch points on a gate are potentially hazardous and must be eliminated or guarded.
- It is extremely unsafe to compensate for a damaged gate by over tightening a clutch or increasing hydraulic pressure.
- An automatic gate operator should not be installed on a gate if people can reach or extend their arms or legs through the gate. Such gates should be guarded or screened to

TROUBLESHOOTING

WARNING! Before you do any work on the control panel, be sure to turn off the main power.

NOTE: Any control panel specific information in the following applies to the 455 D control panel only.

PROBLEM: THE GATE DOES NOT RESPOND TO AN ACTIVATING SIGNAL.

SOLUTION:

You should have at least one operator wired to terminals APM1 and CHM1.

Verify that the LEDs FSWOP, FSWCL, and the STOP are illuminated. If they are not illuminated, be sure that you have closed circuits in the stop and reversing inputs.

Verify that your activating device works properly. OPEN A should illuminate when you signal the gate to open. If OPEN A does not illuminate when you signal the gate, then the problem may be in your activating device. Short across terminals OPEN A and COM. If the short causes the gate to open, then the problem is in the activating device. Repair or replace the device.

PROBLEM: THE GATE DOESN'T OPEN (OR CLOSE) THOUGH THE MOTORS ARE RUNNING.

SOLUTION:

Make sure that the motor is running in the right direction, and make sure the Manual Release mechanism has fully engaged the system.

PROBLEM: THE GATE OPENS BUT DOES NOT CLOSE.

SOLUTION:

Make sure you have selected the desired operating mode.

Verify that the reversing devices are working properly. FSWOP and FSWCL should be illuminated except when a reversing device is triggered. If either does not illuminate, then one of your reversing devices is preventing the gate from responding to your signal. Check your reversing devices.

If no reversing devices are installed, make sure a circuit is installed between appropriate terminals.

PROBLEM: THE GATE DOES NOT FULLY OPEN (OR CLOSE).

SOLUTION:

Check the operator's open/close time selection. You should set a time that is just longer than the rated speed of your model of operator. For example, because the 415 CBAC has a rated opening time of 13 sec, you should set the time at 20 or 25 seconds.

Check to see that there are no obstructions in the path of the gate or that the hinges are not binding.

PROBLEM: THE OPERATOR DOESN'T WORK SMOOTHLY AND THE GATE JERKS AS IT OPENS AND CLOSSES.

SOLUTION:

Make sure the Manual Release Mechanism has fully engaged the worm screw operation of the operator.

Make sure that a flexible gate leaf is not the problem. If the gate leaf flexes, then stiffen the gate or use a slower operator.

NOTES

LIMITED WARRANTY

To the original purchaser only: FAAC International, Inc., warrants, for twenty-four (24) months from the date of invoice, the gate operator systems and other related systems and equipment manufactured by FAAC S.p.A. and distributed by FAAC International, Inc., to be free from defects in material and workmanship under normal use and service for which it was intended *provided* it has been properly installed and operated. FAAC International, Inc.'s obligations under this warranty shall be limited to the repair or exchange of any part of parts manufactured by FAAC S.p.A. and distributed by FAAC International, Inc. Defective products must be returned to FAAC International, Inc., freight prepaid by purchaser, within the warranty period. Items returned will be repaired or replaced, at FAAC International, Inc.'s option, upon an examination of the product by FAAC International, Inc., which discloses, to the satisfaction of FAAC International, Inc., that the item is defective. FAAC International, Inc. will return the warranted item freight prepaid. The products manufactured by FAAC S.p.A. and distributed by FAAC International, Inc., are not warranted to meet the specific requirements, if any, of safety codes of any particular state, municipality, or other jurisdiction, and neither FAAC S.p.A. or FAAC International, Inc., assume any risk or liability whatsoever resulting from the use thereof, whether used singly or in combination with other machines or apparatus.

Any products and parts not manufactured by FAAC S.p.A. and distributed by FAAC International, Inc., will carry only the warranty, if any, of the manufacturer. This warranty shall not apply to any products or parts thereof which have been repaired or altered, without FAAC International, Inc.'s written consent, outside of FAAC International, Inc.'s workshop, or altered in any way so as, in the judgment of FAAC International, Inc., to affect adversely the stability or reliability of the product(s) or has been subject to misuse, negligence, or accident, or has not been operated in accordance with FAAC International, Inc.'s or FAAC S.p.A.'s instructions or has

been operated under conditions more severe than, or otherwise exceeding, those set forth in the specifications for such product(s). Neither FAAC S.p.A. or FAAC International, Inc., shall be liable for any loss or damage whatsoever resulting, directly or indirectly, from the use or loss of use of the product(s). Without limiting the foregoing, this exclusion from liability embraces a purchaser's expenses for downtime or for making up downtime, damages for which the purchaser may be liable to other persons, damages to property, and injury to or death of any persons. Neither FAAC S.p.A. or FAAC International, Inc., assumes nor authorizes any person to assume for them any other liability in connection with the sale or use of the products of FAAC S.p.A. or FAAC International, Inc. The warranty hereinabove set forth shall not be deemed to cover maintenance parts, including, but not limited to, hydraulic oil, filters, or the like. No agreement to replace or repair shall constitute an admission by FAAC S.p.A. or FAAC International, Inc., of any legal responsibility to effect such replacement, to make such repair, or otherwise. This limited warranty extends only to wholesale customers who buy directly through FAAC International, Inc.'s normal distribution channels. FAAC International, Inc., does not warrant its products to end consumers. Consumers must inquire from their selling dealer as to the nature and extent of that dealer's warranty, if any.

This warranty is expressly in lieu of all other warranties expressed or implied including the warranties of merchantability and fitness for use. This warranty shall not apply to products or any part thereof which have been subject to accident, negligence, alteration, abuse, or misuse or if damage was due to improper installation or use of improper power source, or if damage was caused by fire, flood, lightning, electrical power surge, explosion, wind storm, hail, aircraft or vehicles, vandalism, riot or civil commotion, or acts of God.

FAAC International, Inc.
303 Lexington Avenue
Cheyenne, WY 82007
www.faacusa.com