

The **NiceBar** System

New range of road barrier systems to control accesses in public and private parking areas, even where traffic is heavy.

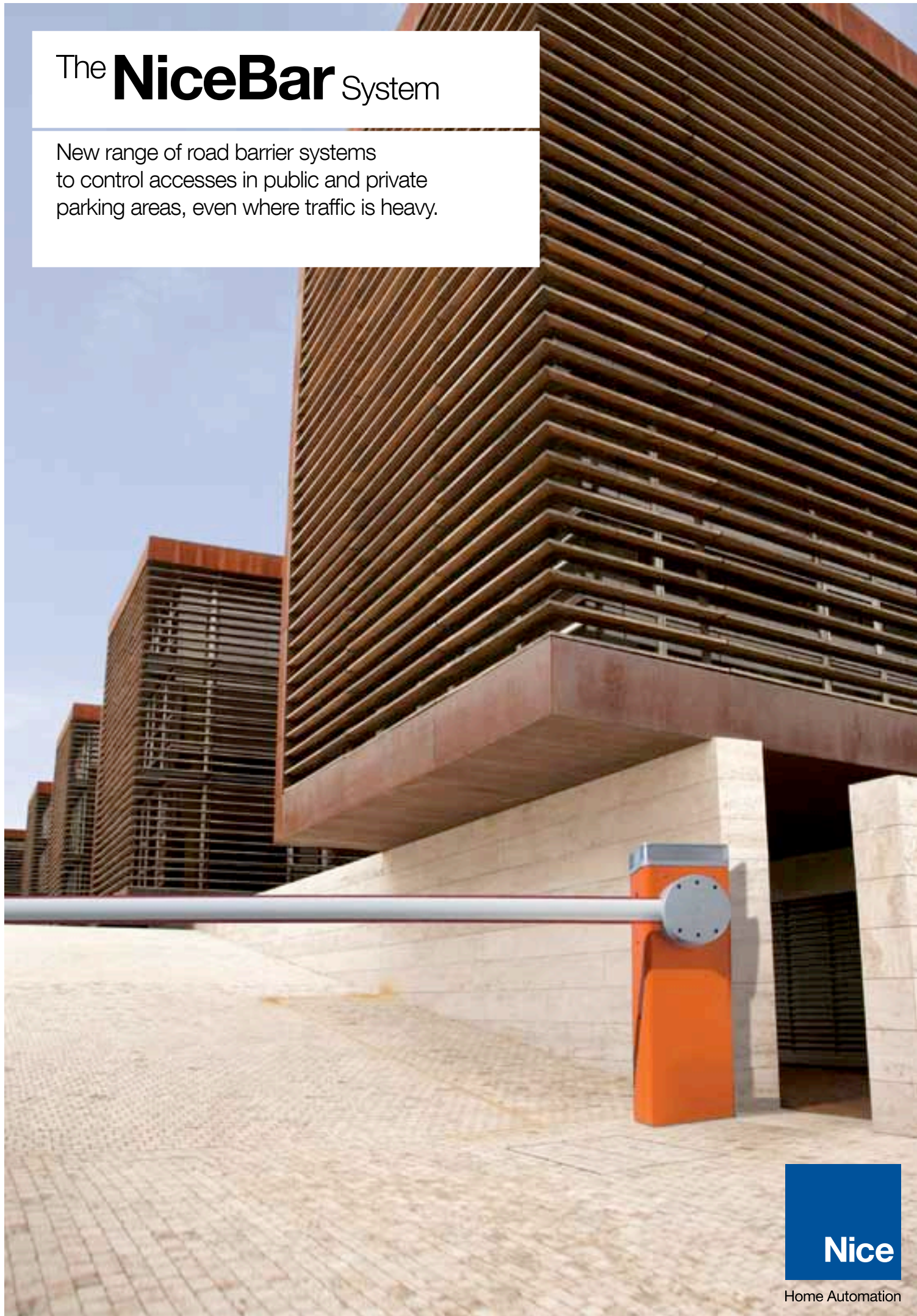

Nice

Home Automation



L/M/S Bar **Barrier gate** **operators** **for all sizes**

New range of barrier gate operators to control road access to car parks, private and condominial transit areas, including high traffic ones.

Powerful and fast: 5 models in 3 standard versions, up to 7 modular bars from 3 to 9 m.

Easy transport and optimised management in the warehouse.



Safe

Integrable flashing or traffic light.
Nightlight function for on-site lighting. Vandal-proof thanks to the tough aluminium case.



Nice Road Barrier

High performing, reliable and durable.
Elegant, streamlined design.
Carefully selected materials.
Greater convenience, safety at all times.



Solemyo System

Solemyo solar power kit for the automation of gates, garage doors and barriers even a long way from electricity supplies, with no need for expensive, unsightly trench digging.



Opera System

For user-friendly, safe control, programming and monitoring of automation systems, with impressive time savings.



BlueBUS

The BlueBUS system allows connection of all system devices using just two wires. Quick installation and easy updating at any time!

**Elliptical section bar
with high resistance
to gusts of wind.
Led signal lights.**



User-friendly compact design

Quick and easy access to internal components with separate enclosures for electronics and mechanics to protect from potential risks. The control unit, located in the upper part of the barrier body, can be reached by simple removing the cover.



Intelligent

Photocells can be fitted in the specially designed seats in the inner part of the barrier body. Integrated loop detector management.



Power and reliability

New high resistance balancing springs guarantee up to 1,000,000 operations. Powerful and fast 24 Vdc gearmotor. Maximum protection: steel housing with protective cataphoresis treatment and paint finish, also available in stainless steel version.



Integrated solutions for all requirements



Nice S/M/L Bar

Guide to the selection and composition of bars and accessories

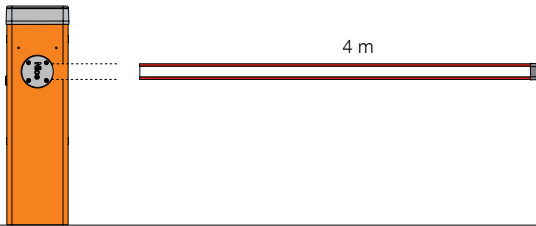

SBAR

- **With specific 4 m bar**
Provision for:
protective rubber trim
and indicator lights

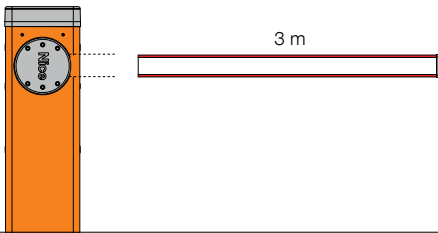

M3BAR

- **With 3 m bar**
Provision for:
protective rubber trim
and indicator lights

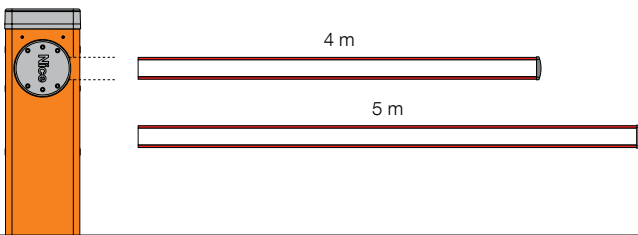

M5BAR

- **With 4 m bar**
Provision for:
protective rubber trim,
indicator lights,
rack, mobile stand
- **With 5 m bar**
Provision for:
protective rubber trim
and indicator lights

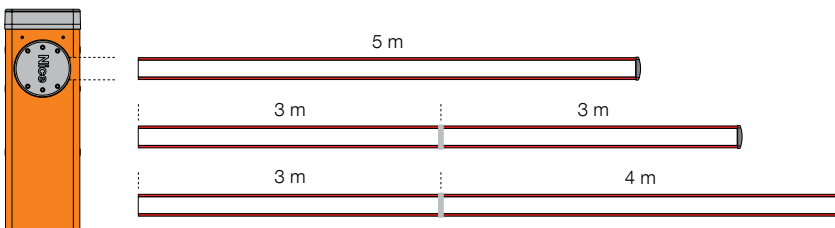

M7BAR

- **With 5 m bar**
Provision for:
protective rubber trim, indicator lights,
rack, mobile stand
 - **With bar up to 6 m (3+3 m)***
Provision for:
protective rubber trim, indicator lights,
rack, mobile stand
 - **With bar up to 7 m (3+4 m)***
Provision for:
protective rubber trim
and indicator lights
- *Use **XBA9** joint to assemble bars

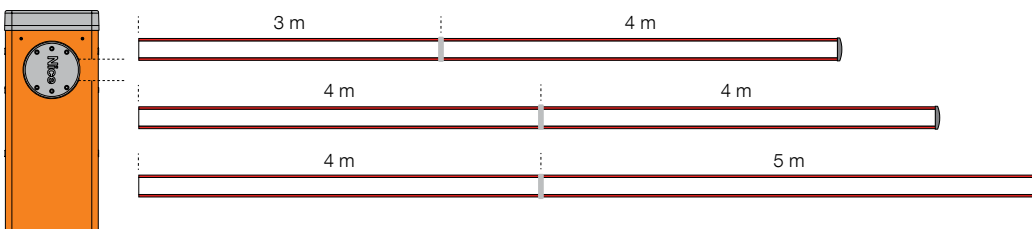

LBAR

- **With bar of 7 m (3+4 m)***
Provision for:
protective rubber trim, indicator lights,
rack, mobile stand
 - **With bar of 8 m (4+4 m)***
Provision for:
protective rubber trim, indicator lights,
rack, mobile stand
 - **With bar of 9 m (4+5 m)***
Provision for:
protective rubber trim
and indicator lights
- *Use **XBA9** joint to assemble bars

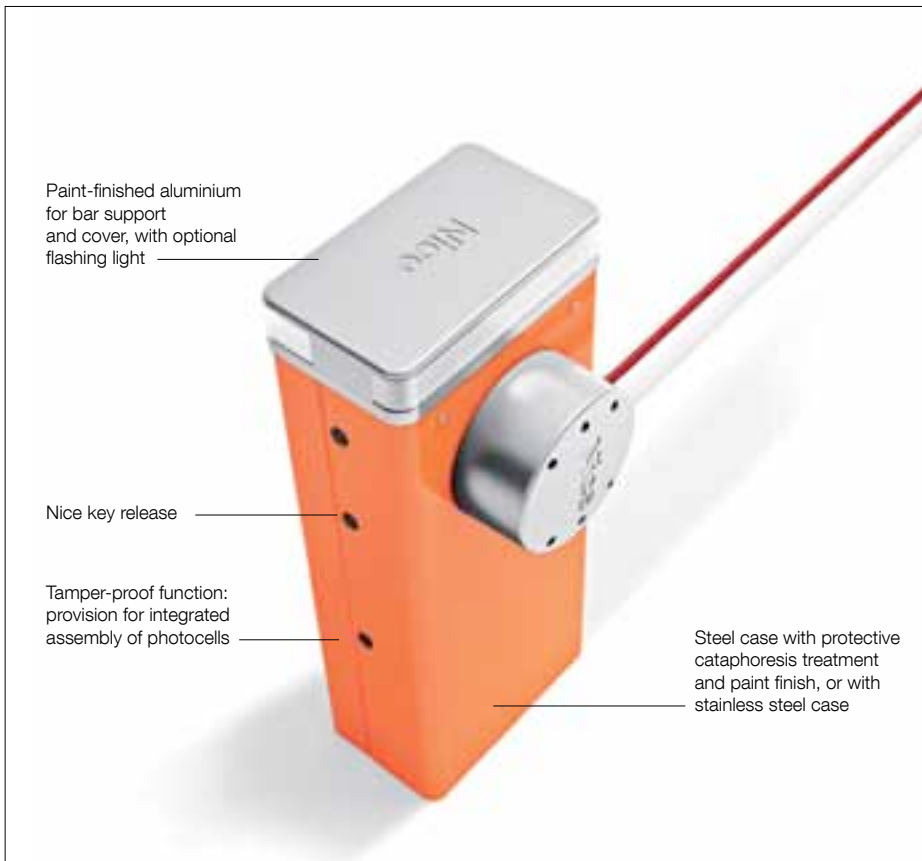

Electromechanical road barrier system for control of road access.
24 Vdc gearmotor with built-in control unit and loop detector.

Powerful and fast, for bars from 7 to 9 m.

Modular: are easily assembled using the aluminium expansion joint.

Possibility for intelligent control of two opposing automations thanks to **“master/slave” function.**

Strength and reliability: robust structure in steel, new high strength balancing springs guaranteed up to 1,000,000 opening and closing operations and elliptical section bar with high wind-gust resistance.

Optional flashing or traffic light can be integrated in cover.

Encoder movement control and electromechanical limit switches.

More comfort and safety in programming and maintenance phases: the separate enclosures for electronics and mechanics protect internal parts from potential risks.

Rapid and easy access to the control unit located in the upper section of the barrier body.

Simple fixture of the completely concealed photocells onto the specially designed seats on the barrier body.

More safety and reliability: obstacle detection and monitoring of motor absorption during automation movement.

Automatic fault diagnostics during operation with consequent signalling of fault type through specific flash sequences.

Provision for connection of latest generation optical and resistive sensitive edges (with 8.2 KOhm resistance).

Energy saving: the system sets to standby when not in use to save consumption.

No blackouts: emergency backup power with the optional batteries housed inside the case.

Release from side with metal key, can be installed on either side.

For bars up to 9 m, irreversible 230 Vac, 24 Vdc motor, with foundation plate:

Code	Description
LBAR	With steel case with protective cataphoresis treatment and paint finish
LBARI	With stainless steel case

Technical specifications

	LBAR	LBARI
Code		
Electrical data		
Power supply (Vac 50/60 Hz)	230	
Power supply (Vdc)	24	
Absorption (A)	1,3	
Power (W)	160	
Performance data		
Speed (s)	8 ÷ 12	
Torque (Nm)	400	
Work cycle (cycles/hour)	150	
Dimensional and general data		
Protection level (IP)	54	
Working temp. (°C Min/Max)	-20 ÷ +50	
Dimensions (mm)	500x299x1215 h	
Peso (kg)	98	

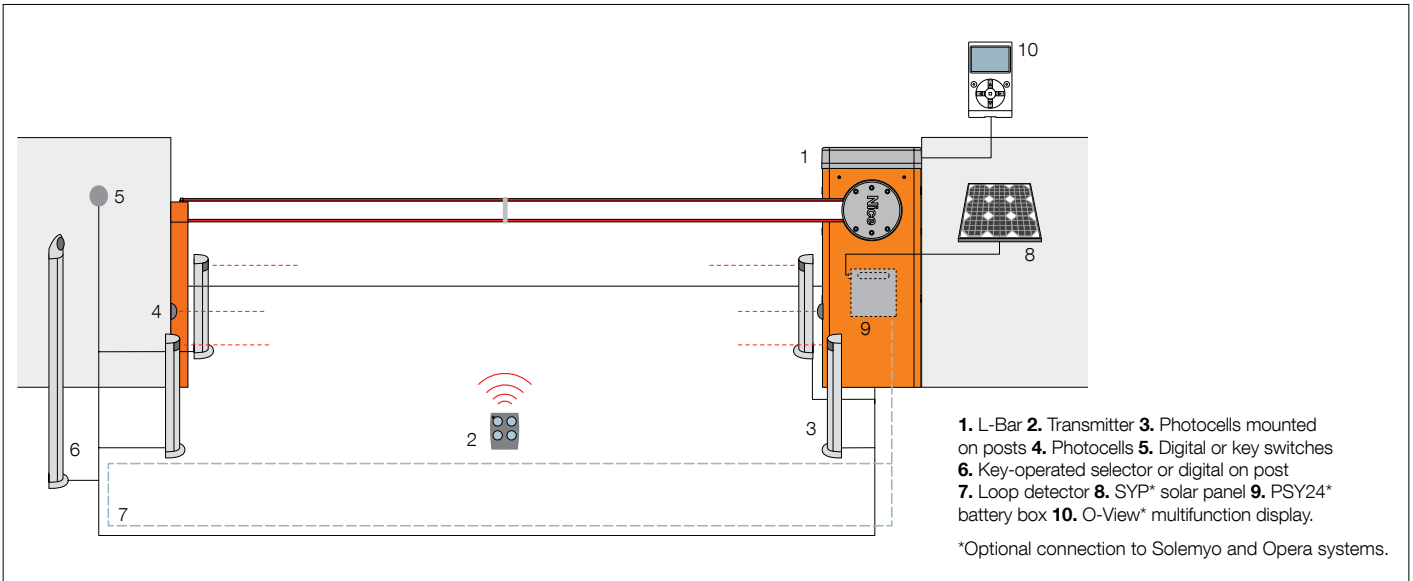

Accessories

Code	Description	Pc/pack
XBA3	Spare control unit	1
PS224	24 Vdc buffer battery	1
XBA15	White paint-finished aluminium bar 69x92x3150 mm	1
XBA14	White paint-finished aluminium bar 69x92x4150 mm	1
XBA5	White paint-finished aluminium bar 69x92x5150 mm	1
XBA9	Expansion joint	1
XBA13	Rubber impact protection strip. Length 1 m	9
WA10	Red adhesive reflector strips	24
XBA18	Indicator lights for click fixture on upper or lower side of bar. Length 8 m	1
XBA8	Integrable traffic light	1
XBA7	Integrable flashing light	1
WA13	Aluminium rack up to 2 m	1
XBA17	Anchorage base with clamps, for LBAR	1
WA12	Mobile stand for bars - <i>New fully reinforced version</i>	1
WA11	Adjustable stand for bars	1

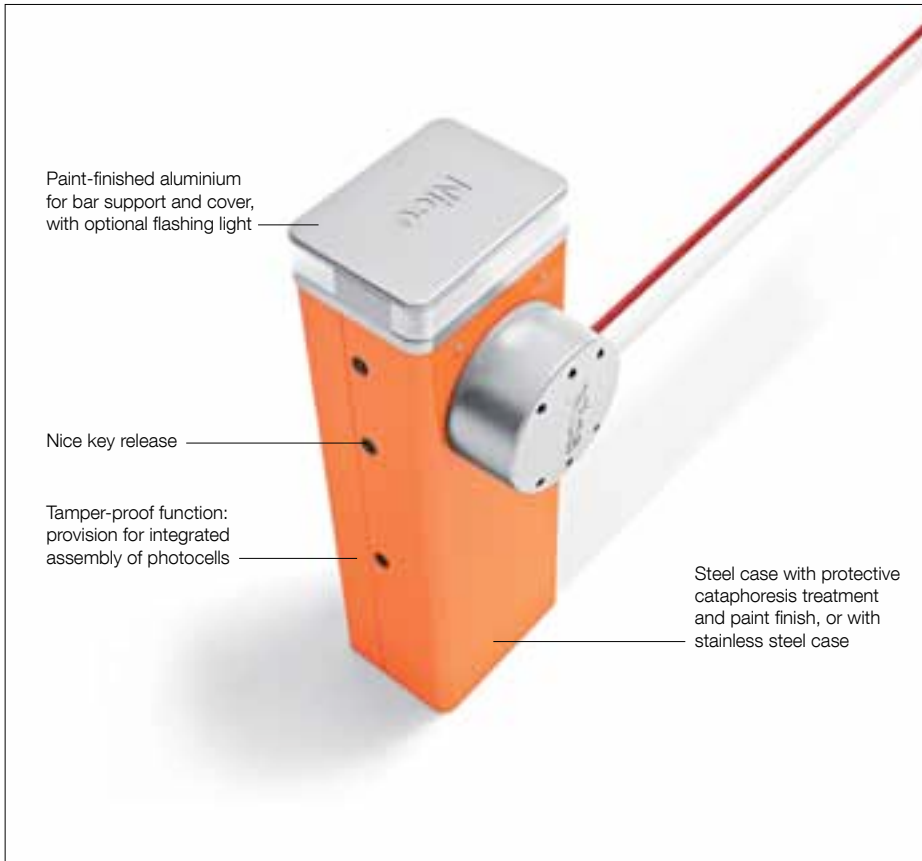

Electromechanical road barrier system for control of road access.
 24 Vdc gearmotor with built-in control unit and loop detector.
For bars up from 3 to 7 m.

Modular: are easily assembled using the aluminium expansion joint.

Possibility for intelligent control of two opposing automations thanks to **“master/slave” function.**

Strength and reliability: robust structure in steel, new high strength balancing springs guaranteed up to 1,000,000 opening and closing operations and elliptical section bar with high wind-gust resistance.

Optional flashing or traffic light can be integrated in cover.

Encoder movement control and electromechanical limit switches.

More comfort and safety in programming and maintenance phases: the separate enclosures for electronics and mechanics protect internal parts from potential risks.

Rapid and easy access to the control unit located in the upper section of the barrier body.

Simple fixture of the completely concealed photocells onto the specially designed seats on the barrier body.

More safety and reliability: obstacle detection and monitoring of motor absorption during automation movement.

Automatic fault diagnostics during operation with consequent signalling of fault type through specific flash sequences.

Provision for connection of latest generation optical and resistive sensitive edges (with 8.2 KOhm resistance).

Energy saving: the system sets to standby when not in use to save consumption.

No blackouts: emergency backup power with the optional batteries housed inside the case.

Release from side with metal key, can be installed on either side.

With bar up to 3 m, irreversible 230 Vac, 24 Vdc motor, with foundation plate:

Code	Description
M3BAR	With steel case with protective cataphoresis treatment and paint finish
M3BARI	With stainless steel case

With bar up to 4 or 5 m, irreversible 230 Vac, 24 Vdc motor, with foundation plate:

Code	Description
M5BAR	With steel case with protective cataphoresis treatment and paint finish
M5BARI	With stainless steel case

With bar up to 5, 6 or 7 m, irreversible 230 Vac, 24 Vdc motor, with foundation plate:

Code	Description
M7BAR	With steel case with protective cataphoresis treatment and paint finish
M7BARI	With stainless steel case

Technical specifications

Code	M3BAR	M3BARI	M5BAR	M5BARI	M7BAR	M7BARI
Electrical data						
Power supply (Vac 50/60 Hz)	230					
Power supply (Vdc)	24					
Absorption (A)	1,3		1,1		1,1	
Power (W)	150		110		110	
Performance data						
Speed (s)	1,5 ÷ 4		3 ÷ 6		6 ÷ 10	
Torque (Nm)	100		200		300	
Work cycle (cycles/hour)	500		350		200	
Dimensional and general data						
Protection level (IP)	54					
Working temp. (°C Min/Max)	-20 ÷ +50					
Dimensions (mm)	400x299x1215 h					
Peso (kg)	80			85		

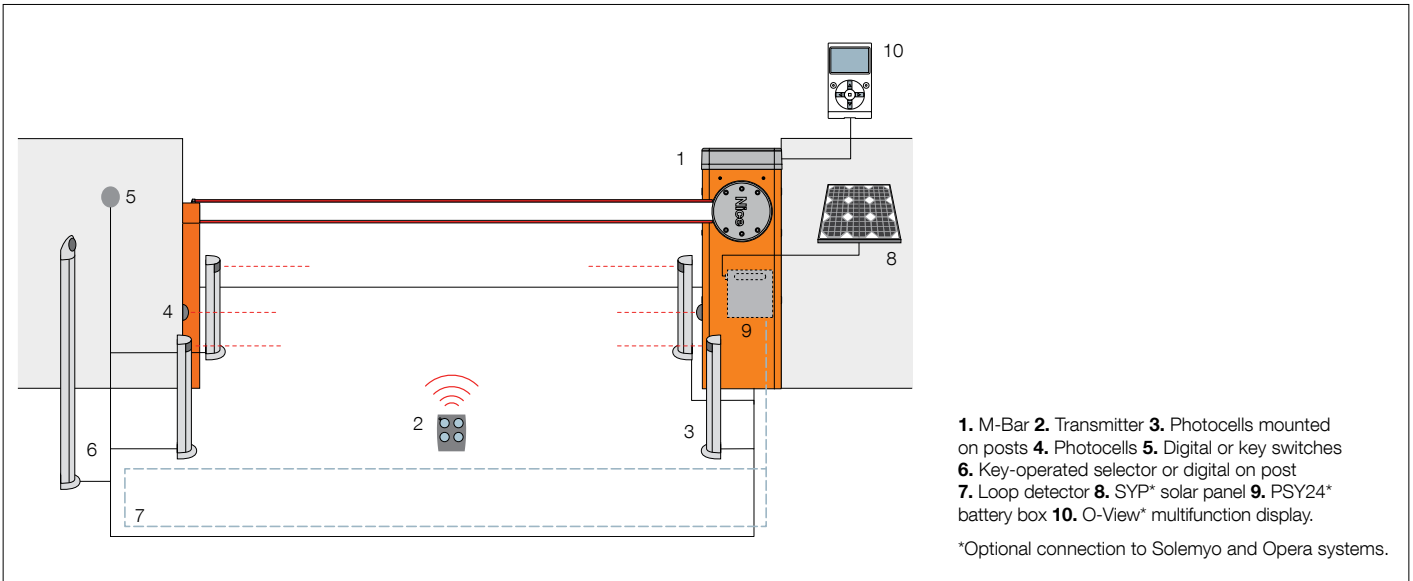

Accessories for M3BAR, M5BAR, M7BAR

Code	Description	Pc/pack
XBA3	Spare control unit	1
PS224	24 Vdc buffer battery	1
XBA13	Rubber impact protection strip. Length 1 m	9
WA10	Red adhesive reflector strips	24
XBA8	Integrable traffic light	1
XBA7	Integrable flashing light	1
XBA16	Anchorage base with clamps, for MBAR	1
WA11	Adjustable stand for bars	1

Accessories for M3BAR

Code	Description	Pc/pack
XBA15	White paint-finished aluminium bar 69x92x3150 mm	1
XBA4	Indicator lights for click fixture on upper or lower side of bar. Length 4 m	1
XBA10	Pivoting connection for bars up to 4 m	1
XBA11	Joint for bars XBA15	1

Accessories for M5BAR

Code	Description	Pc/pack
XBA14	White paint-finished aluminium bar 69x92x4150 mm	1
XBA5	White paint-finished aluminium bar 69x92x5150 mm	1
XBA4	Indicator lights for click fixture on upper or lower side of bar. Length 4 m	1
XBA6	Indicator lights for click fixture on upper or lower side of bar. Length 6 m	1
XBA10	Pivoting connection for bars up to 4 m	1
XBA11	Joint for bars XBA14	1
WA12	Mobile stand for bars - <i>New fully reinforced version</i>	1
WA13	Aluminium rack up to 2 m	1

Accessories for M7BAR

Code	Description	Pc/pack
XBA15	White paint-finished aluminium bar 69x92x3150 mm	1
XBA14	White paint-finished aluminium bar 69x92x4150 mm	1
XBA5	White paint-finished aluminium bar 69x92x5150 mm	1
XBA9	Expansion joint	1
XBA6	Indicator lights for click fixture on upper or lower side of bar. Length 6 m	1
XBA18	Indicator lights for click fixture on upper or lower side of bar. Length 8 m	1
WA12	Mobile stand for bars - <i>New fully reinforced version</i>	1
WA13	Aluminium rack up to 2 m	1

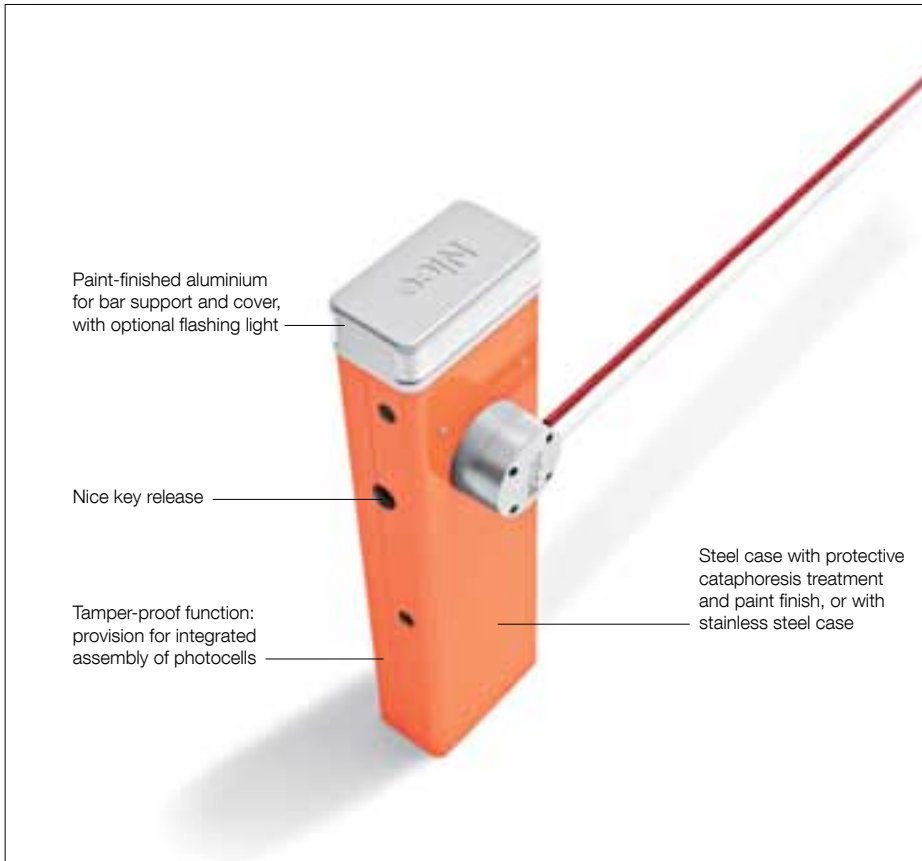

Electromechanical road barrier system for control of road access.

24 Vdc gearmotor with built-in control unit.

For bar up to 4 m.

Strength and reliability: robust structure in steel, new high strength balancing springs guaranteed up to 1,000,000 opening and closing operations and elliptical section bar with high wind-gust resistance.

Optional flashing or traffic light can be integrated in cover.

More comfort and safety in programming and maintenance phases: the separate enclosures for electronics and mechanics protect internal parts from potential risks.

Rapid and easy access to the control unit located in the upper section of the barrier body.

Simple fixture of the completely concealed photocells onto the specially designed seats on the barrier body.

More safety and reliability: obstacle detection and monitoring of motor absorption during automation movement.

Automatic fault diagnostics during operation with consequent signalling of fault type through specific flash sequences.

Provision for connection of latest generation optical and resistive sensitive edges (with 8.2 KOhm resistance).

Energy saving: the system sets to standby when not in use to save consumption.

No blackouts: emergency backup power with the optional batteries housed inside the case.

Release from side with Nice triangular key, can be installed on either side.

With bar up to 4 m, irreversible 230 Vac, 24 Vdc motor, with foundation plate:

Code	Description
SBAR	With steel case with protective cataphoresis treatment and paint finish
SBARI	With stainless steel case

Technical specifications

	SBAR	SBARI
Electrical data		
Power supply (Vac 50/60 Hz)	230	
Power supply (Vdc)	24	
Absorption (A)	1	
Power (W)	300	
Performance data		
Speed (s)	<4	
Torque (Nm)	100	
Work cycle (cycles/hour)	100	
Dimensional and general data		
Protection level (IP)	44	
Working temp. (°C Min/Max)	-20 ÷ +50	
Dimensions (mm)	330x180x1180 h	
Peso (kg)	46	

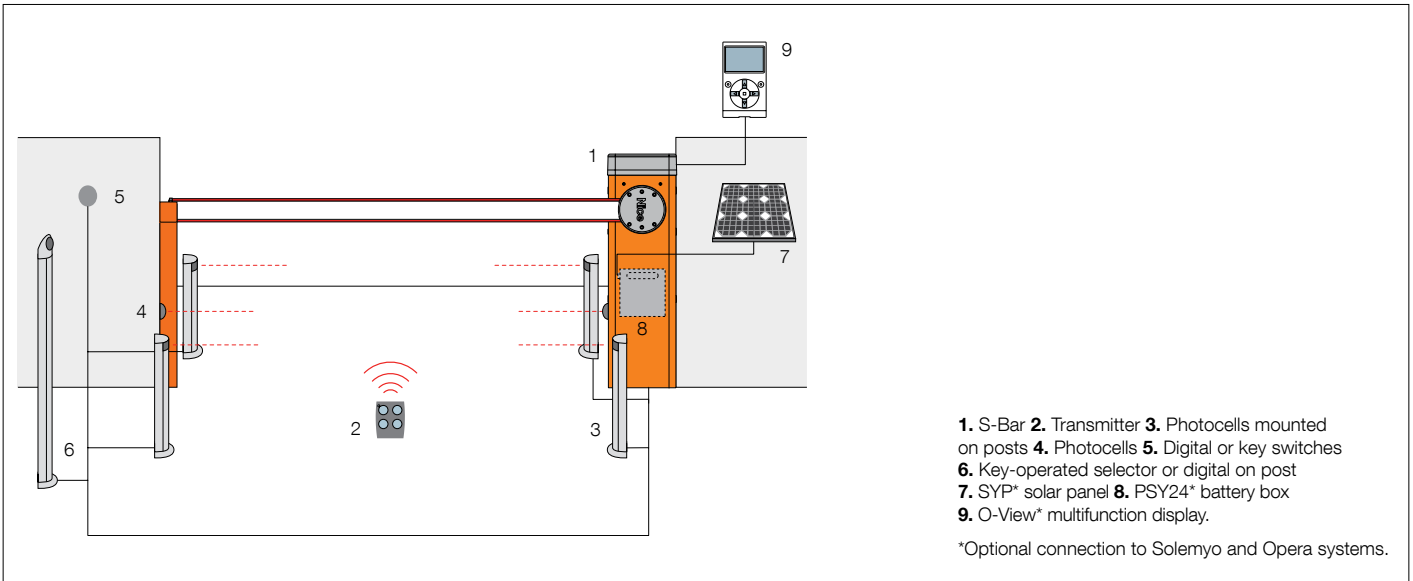

Accessories

Code	Description	Pc/pack
XBA20	Spare control unit for SBAR	1
PS124	24 V battery with integrated battery charger	1
XBA19	White paint-finished aluminium bar 45x58x4000 mm	1
XBA13	Rubber impact protection strip. Length 1 m	9
WA10	Red adhesive reflector strips	24
SIA1	Anchorage base with clamps	1
XBA7	Integrable flashing light	1
XBA4	Indicator lights for click fixture on upper or lower side of bar. Length 4 m	1
WA11	Adjustable stand for bars	1