

615

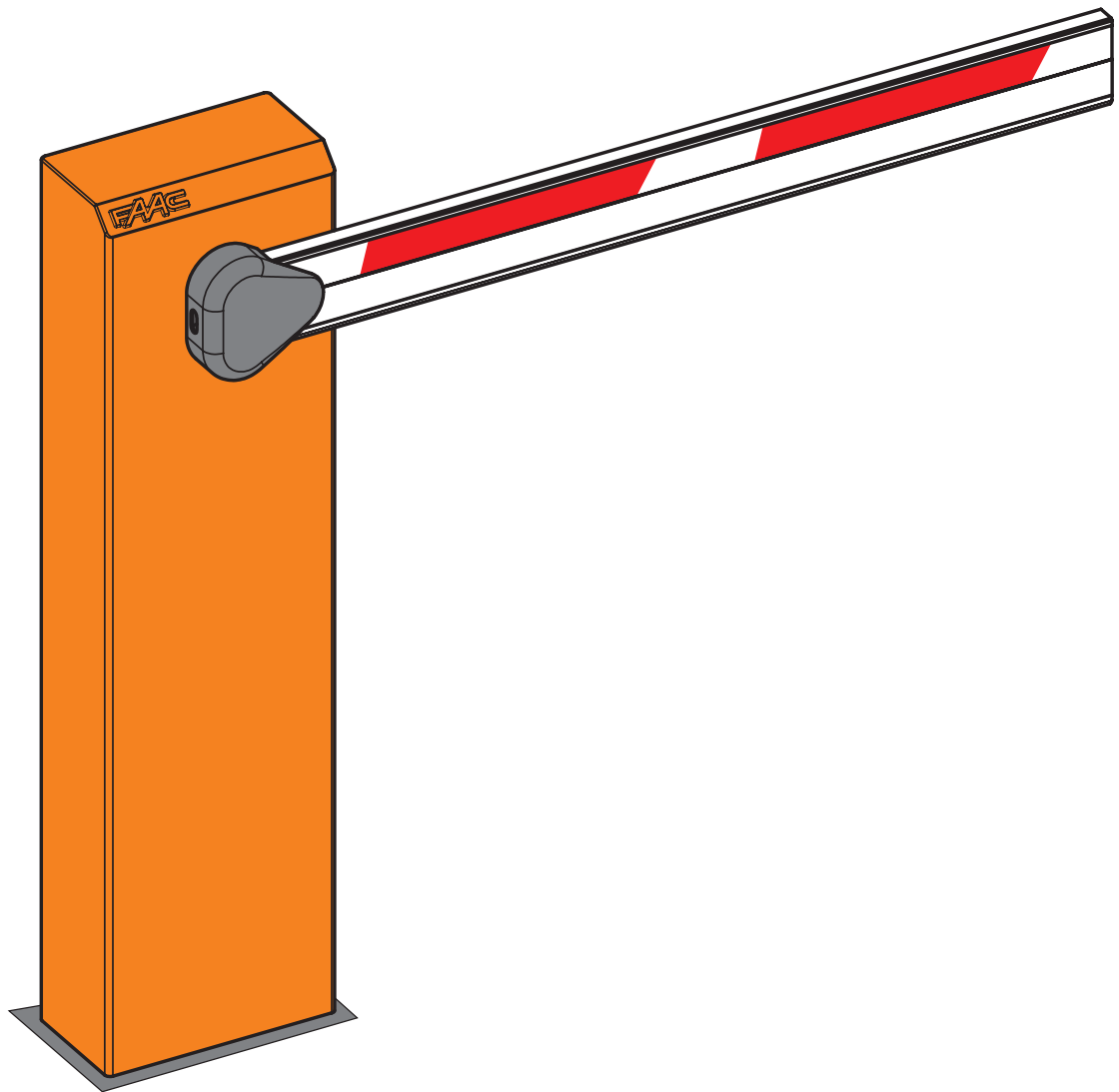

FAAC

Leggere completamente questo manuale di istruzioni prima di iniziare l'installazione del prodotto.



Il simbolo evidenzia le note importanti per la sicurezza delle persone e l'integrità dell'automazione.



Il simbolo richiama l'attenzione sulle note riguardanti le caratteristiche od il funzionamento del prodotto.

Read this instruction manual to the letter before you begin to install the product.



Symbol highlights notes that are important for people's safety and for the good condition of the automated system.



Symbol draws your attention to the notes about the product's characteristics or operation.

Lire ce manuel d'instructions dans son entier avant de commencer l'installation du produit.



Le symbole met en évidence les remarques pour la sécurité des personnes et le parfait état de l'automatisme.



Le symbole attire l'attention sur les remarques concernant les caractéristiques ou le fonctionnement du produit.

Vor der Installation des Produkts sind die Anweisungen vollständig zu lesen.



Mit dem Symbol sind wichtige Anmerkungen für die Sicherheit der Personen und den störungsfreien Betrieb der Automation gekennzeichnet.



Mit dem Symbol wird auf Anmerkungen zu den Eigenschaften oder dem Betrieb des Produkts verwiesen.

Lean completamente este manual de instrucciones antes de empezar la instalación del producto.



El símbolo identifica notas importantes para la seguridad de las personas y para la integridad de la automatización.



El símbolo llama la atención sobre las notas relativas a las características o al funcionamiento del producto.

Lees deze instructiehandleiding helemaal door alvorens het product te installeren.



Het symbool is een aanduiding van opmerkingen die belangrijk zijn voor de veiligheid van personen en voor een goede automatische werking.



Het symbool vestigt de aandacht op opmerkingen over de eigenschappen of de werking van het product.

INDEX

CE DECLARATION OF CONFORMITY FOR MACHINES 2

WARNINGS FOR THE INSTALLER 2

1 DESCRIPTION AND TECHNICAL SPECIFICATIONS 3

1.1 MAXIMUM USE CURVE 3

2 ELECTRIC PREPARATIONS (standard system) 4

3 DIMENSIONS 4

4 INSTALLING THE AUTOMATED SYSTEM 4

4.1 PRELIMINARY CHECKS 4

4.2 MASONRY FOR FOUNDATION PLATE 4

4.3 INSTALLING THE UPRIGHT 4

4.4 INSTALLING THE BEAM 4

4.5 INSTALLING AND ADJUSTING THE BALANCING SPRING 4

5 BALANCING SPRINGS 6

5.1 SPRINGS FOR RECTANGULAR BEAMS WITH SKIR 6

5.2 SPRINGS FOR RECTANGULAR BEAMS WITH FOOT AND WITH SKIRT AND FOOT 6

5.3 SPRINGS FOR 615BPR RAPIDA (RAPIDE) 6

5.4 SPRINGS FOR ROUND BARS 6

5.5 TRANSFORMATION FROM RIGHT TO LEFT VERSION 6

6 START-UP 7

6.1 ADJUSTING THE TRANSMITTED TORQUE 7

6.2 ADJUSTING THE MECHANICAL TRAVEL LIMITS 7

6.3 ADJUSTING THE MAGNETIC TRAVEL LIMITS 7

6.4 AUTOMATED SYSTEM TEST 7

7 MANUAL MODE OPERATION 7

8 RESTORING NORMAL OPERATION MODE 7

9 AVAILABLE ACCESSORIES 8

10 MAINTENANCE 8

11 REPAIRS 8

ENGLISH

Notes on reading the instruction

Read this installation manual to the full before you begin installing the product.

The symbol  indicates notes that are important for the safety of persons and for the good condition of the automated system.

The symbol  draws your attention to the notes on the characteristics and operation of the product.

CE DECLARATION OF CONFORMITY FOR MACHINES (DIRECTIVE 98/37/EC)

Manufacturer: FAAC S.p.A.

Address: Via Calari, 10 - 40069 Zola Predosa BOLOGNA - ITALY

Declares that: Barrier mod. 615BPR,

- is built to be integrated into a machine or to be assembled with other machinery to create a machine under the provisions of Directive 98/37/EC;
- conforms to the essential safety requirements of the other following EEC directives:

2006/95/EC Low Voltage Directive
2004/108/EEC Electromagnetic Compatibility Directive

Furthermore, the manufacturer declares that the machinery must not be put into service until the machine into which it will be integrated or of which it will become a component has been identified and its conformity to the conditions of Directive 89/392/EEC and subsequent modifications assimilated in Italian National legislation under Presidential Decree No. 459 of 24 July 1996 has been declared..

Bologna, 1st September 2009

The Managing Director

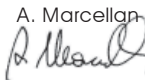
A. Marcellan

ENGLISH

WARNINGS FOR THE INSTALLER GENERAL SAFETY OBLIGATIONS

- 1) **ATTENTION! To ensure the safety of people, it is important that you read all the following instructions. Incorrect installation or incorrect use of the product could cause serious harm to people.**
- 2) Carefully read the instructions before beginning to install the product.
- 3) Do not leave packing materials (plastic, polystyrene, etc.) within reach of children as such materials are potential sources of danger.
- 4) Store these instructions for future reference.
- 5) This product was designed and built strictly for the use indicated in this documentation. Any other use, not expressly indicated here, could compromise the good condition/operation of the product and/or be a source of danger.
- 6) FAAC declines all liability caused by improper use or use other than that for which the automated system was intended.
- 7) Do not install the equipment in an explosive atmosphere: the presence of inflammable gas or fumes is a serious danger to safety.
- 8) The mechanical parts must conform to the provisions of Standards EN 12604 and EN 12605.
For non-EU countries, to obtain an adequate level of safety, the Standards mentioned above must be observed, in addition to national legal regulations.
- 9) FAAC is not responsible for failure to observe Good Technique in the construction of the closing elements to be motorised, or for any deformation that may occur during use.
- 10) The installation must conform to Standards EN 12453 and EN 12445.
For non-EU countries, to obtain an adequate level of safety, the Standards mentioned above must be observed, in addition to national legal regulations.
- 11) Before attempting any job on the system, cut out electrical power.
- 12) The mains power supply of the automated system must be fitted with an all-pole switch with contact opening distance of 3 mm or greater. Use of a 6A thermal breaker with all-pole circuit break is recommended.
- 13) Make sure that a differential switch with threshold of 0.03 A is fitted upstream of the system.
- 14) Make sure that the earthing system is perfectly constructed and connect metal parts of the closure to it.
- 15) The automated system is supplied with an intrinsic anti-crushing safety device consisting of a torque control. Nevertheless, its tripping threshold must be checked as specified in the Standards indicated at point 10.
- 16) The safety devices (EN 12978 standard) protect any danger areas against **mechanical movement Risks**, such as crushing, dragging, and shearing.
- 17) Use of at least one indicator-light (e.g. FAACLIGHT) is recommended for every system, as well as a warning sign adequately secured to the frame structure, in addition to the devices mentioned at point "16".
- 18) FAAC declines all liability as concerns safety and efficient operation of the automated system, if system components not produced by FAAC are used.
- 19) For maintenance, strictly use original parts by FAAC.
- 20) Do not in any way modify the components of the automated system.
- 21) The installer shall supply all information concerning manual operation of the system in case of an emergency and shall hand over to the user the warnings handbook supplied with the product.
- 22) Do not allow children or adults to stay near the product while it is operating.
- 23) Keep remote controls or other pulse generators away from children, to prevent the automated system from being activated involuntarily.
- 24) Transit is permitted only when the automated system is idle.
- 25) The user must not attempt any kind of repair or direct action whatever and contact qualified personnel only.
- 26) Check at least every 6 months the efficiency of the system, particularly the efficiency of the safety devices (including, where foreseen, the operator thrust force) and of the release devices.
- 27) **Anything not expressly specified in these instructions is not permitted.**

AUTOMATED SYSTEM 615BPR

The 615BPR automated system consists of an aluminium beam with reflex reflectors, and a steel upright subjected to cataphoresis treatment and painted with polyester paint. The upright houses the hydraulic operator and the electronic control unit.

The operator, which moves the beam, consists of a hydraulic power pack and a double-acting cylinder.

The system is supplied with an adjustable torque limitation system. It also includes a device stopping the beam in any position, and a handy manual release command for use in case of power cuts or faults.

The beam and the relevant balancing spring must be ordered by referring to the sales price list.

The 615BPR automated system was designed and built for controlling vehicle access. Do not use for any other purpose.

1 DESCRIPTION AND TECHNICAL SPECIFICATIONS

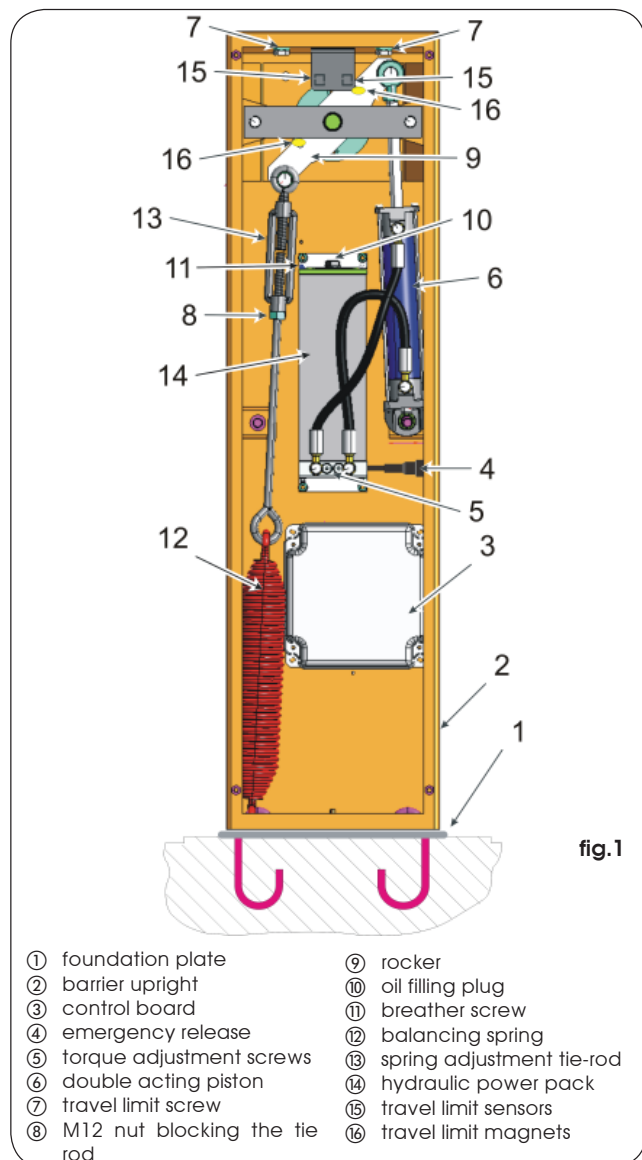

Tab. 1 - Technical specifications "Barrier 615BPR"

BARRIER MODEL	615BPR STD	615BPR RAP
Beam max. length (m)	5	2,5
Max. opening time (sec)	5,7	2,9
Angular speed (rad/sec)	0,28	0,54
Pump flow-rate (l/min)	1,5	3
Max. torque (Nm)	400	300
Types of beam	Rectangular / Rectangular skirt articulated / Round	
Use frequency (at 20°C)	50%	40%
Max. consecutive cycles (at 20°C)	220	340
Power supply	230V~ (+6 -10 %) 50Hz	
Absorbed power (W)	220	
Type of oil	FAAC HP OIL	
Oil quantity (Kg)	0,9	
Thermal protection for winding	120° C	
Torque adjustment system	standard by-pass valves	
Operating ambient temperature	-40 ÷ +55 °C	
Hood protective treatment	cataphoresis	
Hood paint	Polyester RAL 2004	
Protection class	IP 44	
Weight (Kg)	34	
Upright dimensions LxHxP(mm)	270 x 1015 x 140	
Electric motor technical specifications		
RPM	1400	2800
Power (W)	220	
Absorbed current (A)	1	
Power supply	230V~ (+6 -10 %) 50Hz	

1.1 MAXIMUM USE CURVE

The curve makes it possible to establish maximum work time (T) according to use frequency (F).

E.g. The 615 BPR automated system can operate non-stop at a use frequency of 50%.

To ensure efficient operation, operate in the work range under the curve.

Important: The curve is obtained at a temperature of 20°C. Exposure to the direct sun rays can reduce use frequency down to 20%.

Calculation of use frequency

The percentage of effective work time (opening + closing) compared to total time of cycle (opening + closing + pause times).

Calculation formula:

$$\%F = \frac{Ta + Tc}{Ta + Tc + Tp + Ti} \times 100$$

where:

Ta = opening time

Tc = closing time

Tp = pause time

Ti = interval time between one complete cycle and another.

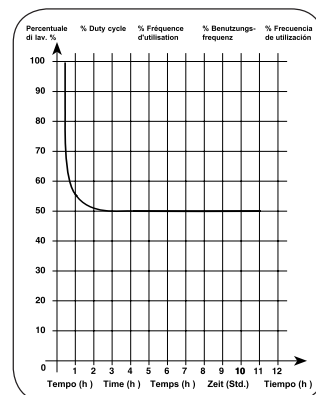

2. ELECTRIC PREPARATIONS (standard system)

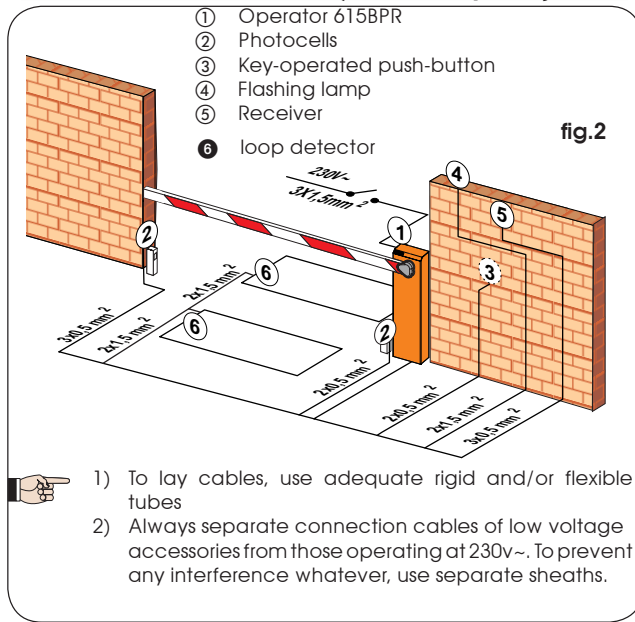

ENGLISH

3 DIMENSIONS

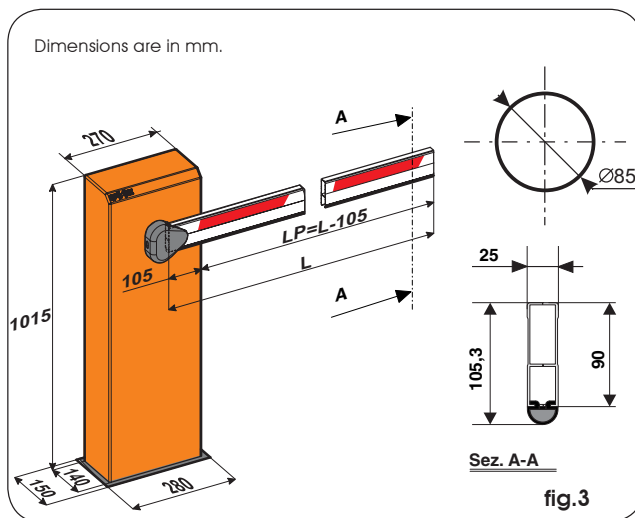

4 INSTALLING THE AUTOMATED SYSTEM

4.1 PRELIMINARY CHECKS

To ensure safety and an efficiently operating automated system, make sure the following conditions are observed:

- When moving, the beam must not, on any account, meet any obstacles or overhead power cables.
- The soil must permit sufficient stability for the foundation plinth.
- There must be no pipes or electrical cables in the plinth excavation area.
- If the barrier body is exposed to passing vehicles, install, if possible, adequate means of protection against accidental impact.

4.2 MASONRY FOR FOUNDATION PLATE

- 1) Make a foundation plate as shown in fig.4 (referred to clayey soil)
- 2) Wall the foundation plate as shown in fig.4, supplying one or more sheaths for routing electrical cables. Using a spirit level, check if the plate is perfectly level. Wait for the cement to set.

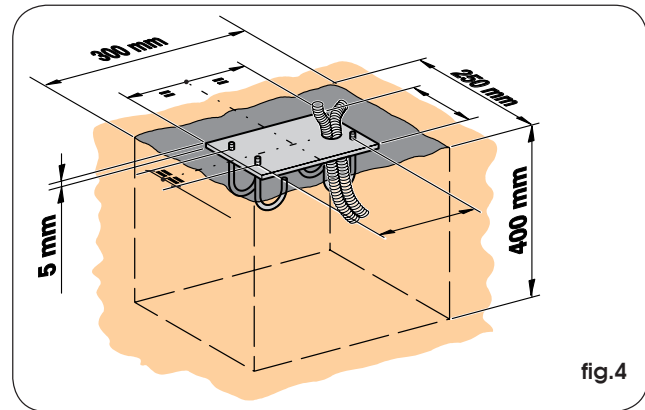

4.3 INSTALLING THE UPRIGHT

- 1) Remove the cover, unscrewing the screws securing it to the upright.
- 2) Using the four nuts and washers supplied, secure the upright on the foundation plate as shown in fig.5. Remember that the hatch of the upright should normally face the building.

4.4 INSTALLING THE BEAM



The 615BPR automated system is always supplied in the right-hand version – for left-hand installation, see chapter 5.5.

- 1) Make sure that the rod of the piston secured to the rocker is completely extended (corresponding to the beam's vertical position).
- 2) Remove and store the breather screw as shown in fig.6
- 3) Assemble the bar as in fig.7a for the rectangular version, or as in fig.7b for the round version.

4.5 INSTALLING AND ADJUSTING THE BALANCING SPRING

- 1) Check if the balancing spring matches the type of beam installed: see chapter 5.
- 2) While keeping the beam in vertical position, assemble the tie rod and spring as shown in fig.8
- 3) Release the operator (see chapter 7) and position the beam at 45°, then adjust the tie-rod and set the spring until the weight of the beam is balanced in that position.
- 4) Restore normal operation as described in chapter 7.

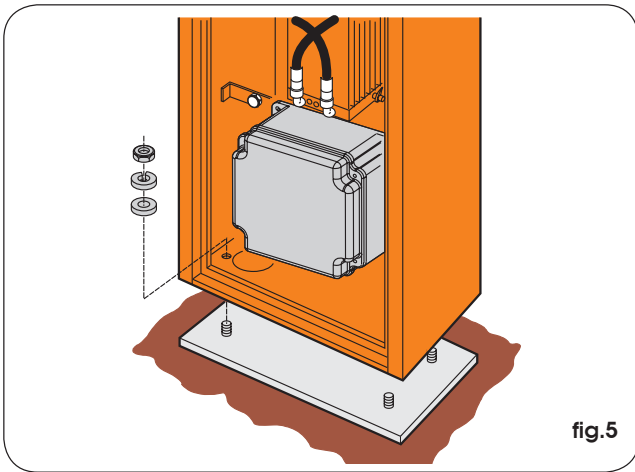

fig.5

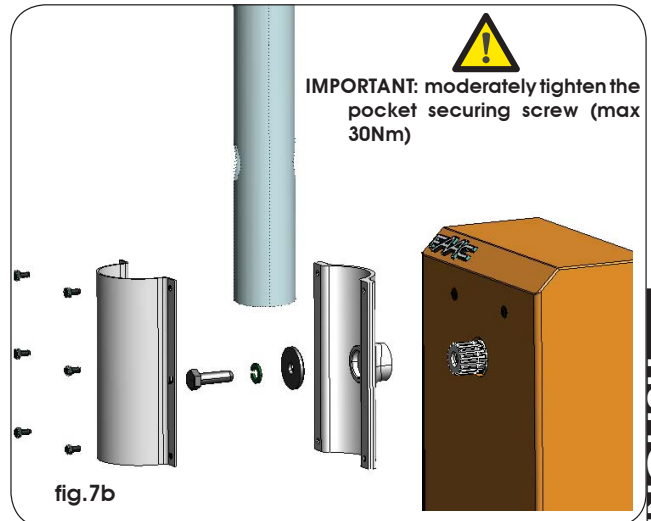

fig.7b

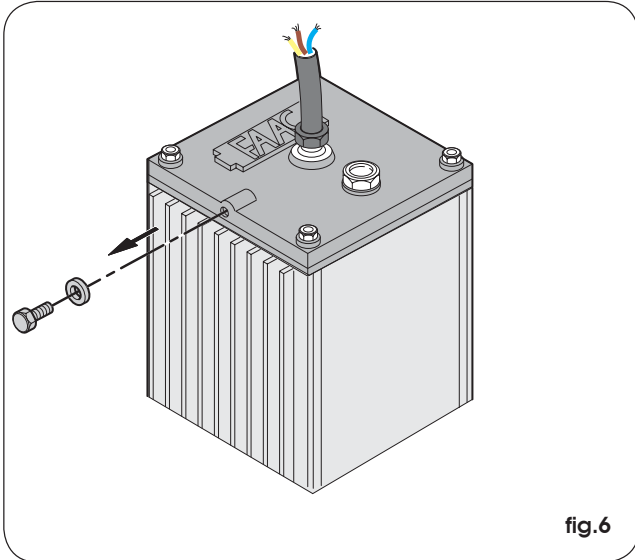

fig.6

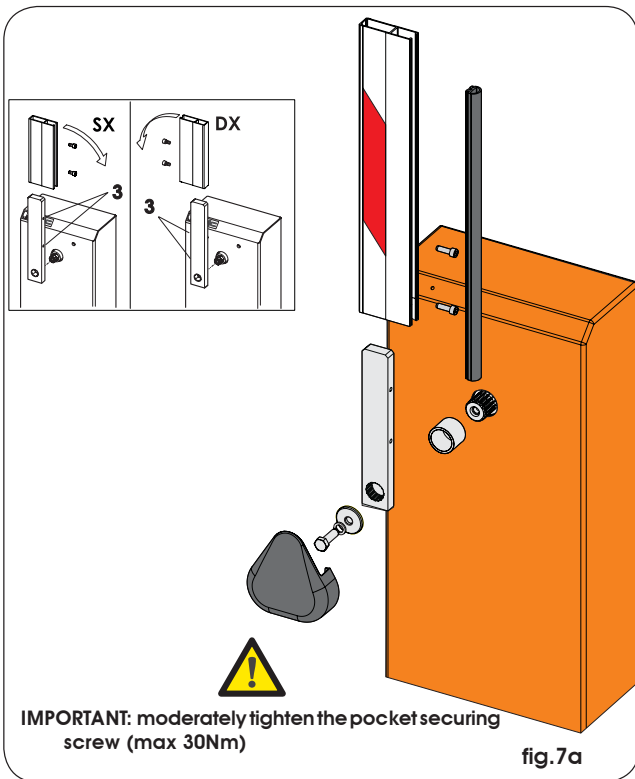

fig.7a

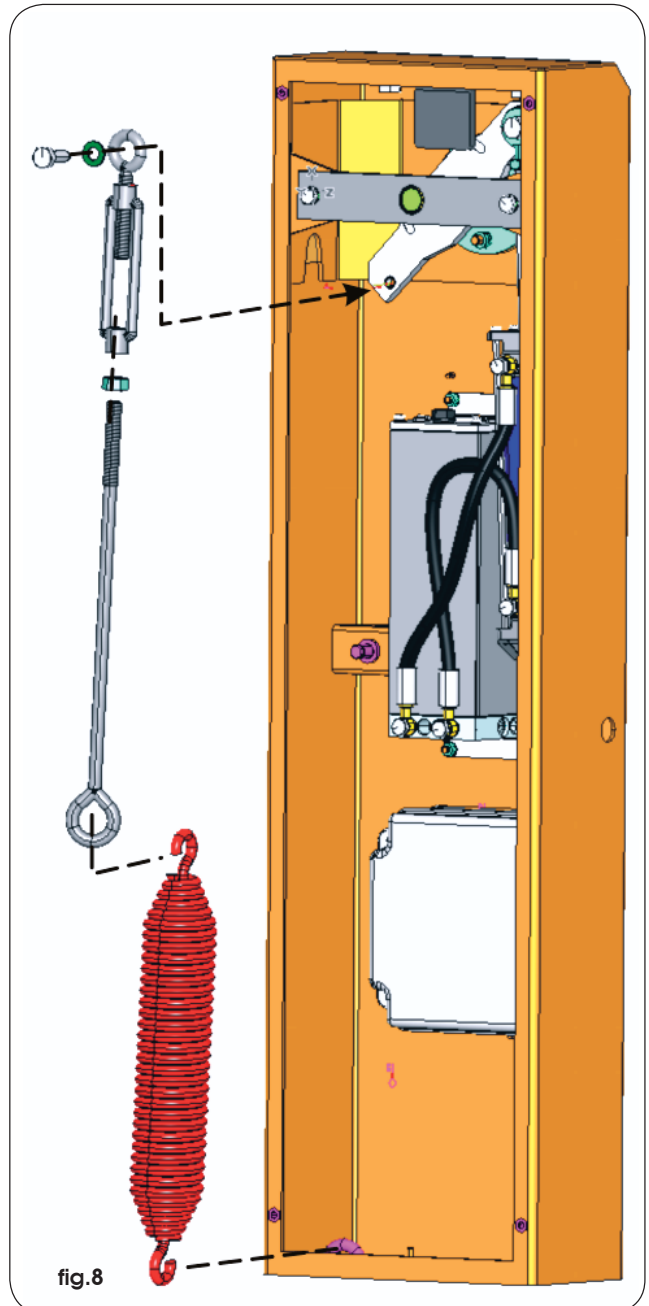

fig.8

5 BALANCING SPRINGS

The 615 BPR automated system requires a balancing spring for the beam, which must be ordered separately. The spring varies according to length and type of beam (rigid, skirt or articulated).

Consult the tables below to see if the spring matches.

5.1 SPRINGS FOR RECTANGULAR BEAMS WITH SKIRT

BALANCING SPRING			
∅	rectangular beam	beam with skirt	code
5,5	1315 – 2315	1315 - 2315	721008
6,0	2316 – 2815	2316 – 2815	721005
7,0	2816 – 3815		721006
7,5		2816 – 3815	721007
8,0	3816 – 4815		721018

5.2 SPRINGS FOR RECTANGULAR BEAMS WITH FOOT AND WITH SKIRT AND FOOT

BALANCING SPRING			
∅	beam with foot	beam with skirt and foot	code
5,5	1315 – 1815	1315 - 1815	721008
6,0	1816 – 2315	1816 – 2315	721005
7,0	2316 – 2815		721006
7,5		2316 – 3315	721007
8,0	2816 – 3815		721018

5.3 FOR 615BPR RAPID

BALANCING SPRING			
∅	rectangular beam	round beam	code
5,5	1315 – 2315	1315 - 2315	721008

5.4 SPRINGS FOR ROUND BARS

BALANCING SPRING		
∅	round beam	code
5,5	1500 – 3000	721008
6	3001 – 4000	721005
7,5	4001 – 5000	721006

5.5 TRANSFORMATION FROM RIGHT TO LEFT VERSION

Procedure for converting a right-hand version to left-hand:

Release the operator.

Loosen the connection (fig.9 ref.A).

Provisionally remove the piston securing screw (fig.9 ref.B) and the seeger ring (fig.9 ref.C).

Rotate the rocker.

Position the piston from the left side and secure it with the screw (fig.9 ref.D) and the seeger (fig.9 ref.E) you had removed.

Tighten the connection (fig.9 ref.F).

Re-lock the operator.

Dismantle the container of the control unit and re-install it on the left of the hood, using the existing holes.

Change over the connectors of the travel-limit sensors (J6 and J9 on the 596/615BPR board).

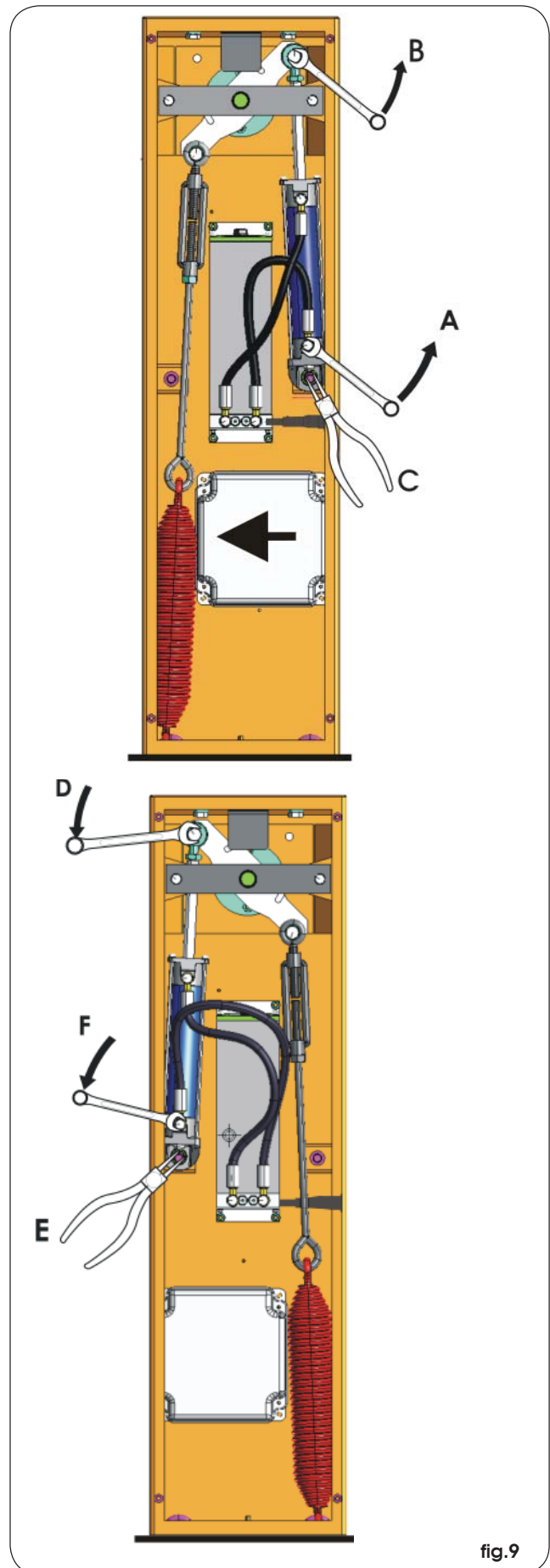

fig.9

6 START-UP

6.1 ADJUSTING THE TRANSMITTED TORQUE

To set the hydraulic system controlling transmitted power, turn the two by-pass screws (fig.10).

The red screw controls closing movement torque.

The green screw controls opening movement torque.

To increase torque, turn the screws clockwise.

To reduce torque, turn the screws anti-clockwise.

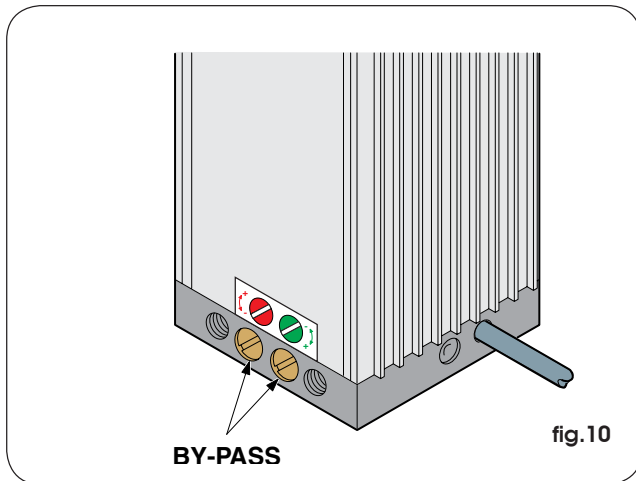

6.2 ADJUSTING THE MECHANICAL TRAVEL LIMITS

Adjust the position of the beam to maximum closing and opening positions, using the travel limit mechanical stops as shown in fig.11.ref.1.

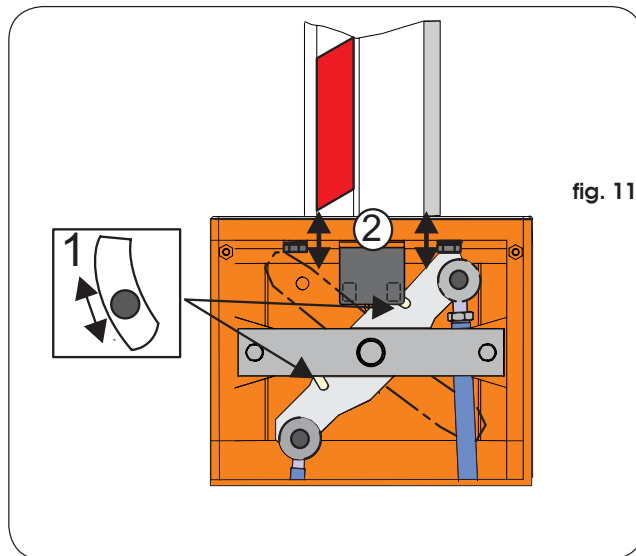

6.3 ADJUSTING THE MAGNETIC TRAVEL LIMITS

The point where the automated system begins to make the slow-down movement can be modified, by moving the magnetic cylinder inside the seat located on the two arms of the rocker in the motion unit (fig.11 - ref.2).

6.4 AUTOMATED SYSTEM TEST

After installation, apply the danger warning sticker on the top of the upright (Fig. 12).

Check operating efficiency of the automated system and all accessories connected to it.

Hand the "User's Manual" to the Client, explain correct operation and use of the barrier, and indicate the potentially dangerous areas of the automated system.

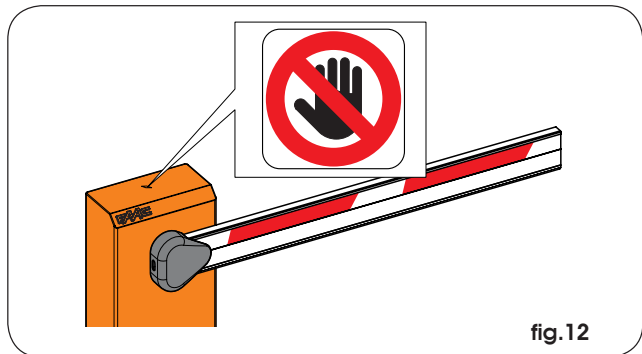

7 MANUAL MODE OPERATION

If the barrier has to be moved manually due to a power cut or fault of the automated system, use the release device as follows.

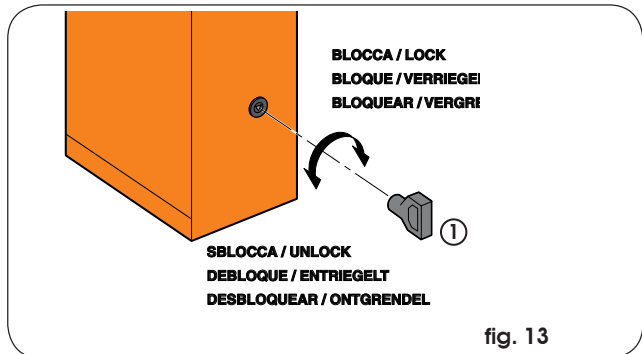

- Fit the standard triangular key (Fig.13) in the lock and turn it **anti-clockwise** through 1 turn.
- Open and close the barrier manually.

8 RESTORING NORMAL OPERATION MODE

To prevent an involuntary impulse from activating the barrier during the manoeuvre, before restoring normal operation, switch off power to the system, and turn the triangular key **clockwise** until it stops, and then remove it.

9 AVAILABLE ACCESSORIES

SKIRT KIT (fig.14)

The skirt kit increases visibility of the beam.
It is available in lengths from 2 m to 3 m.

⚠ If a skirt kit is installed, the balancing spring must be adapted.

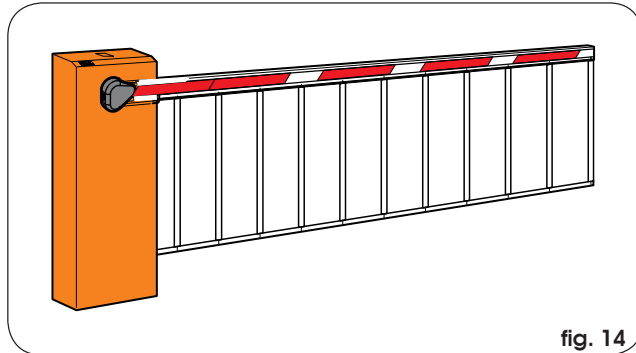

fig. 14

FORK SUPPORT (fig.15)

The fork has two functions:

- it prevents the beam, when closed, from bending or splitting if its end is stressed by extraneous forces.
- it allows the beam to rest when closed and thus prevents the profile bending downward.

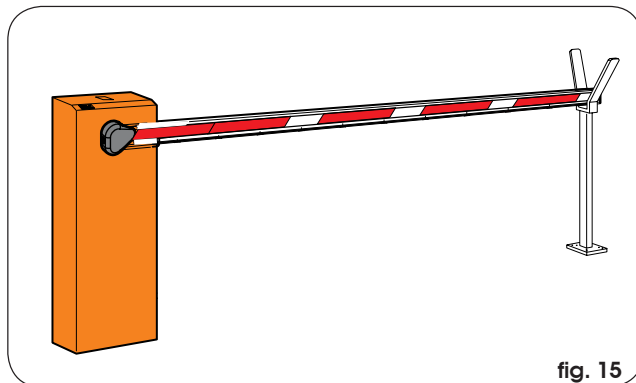

fig. 15

POSITIONING THE FORK SUPPORT FOUNDATION PLATE

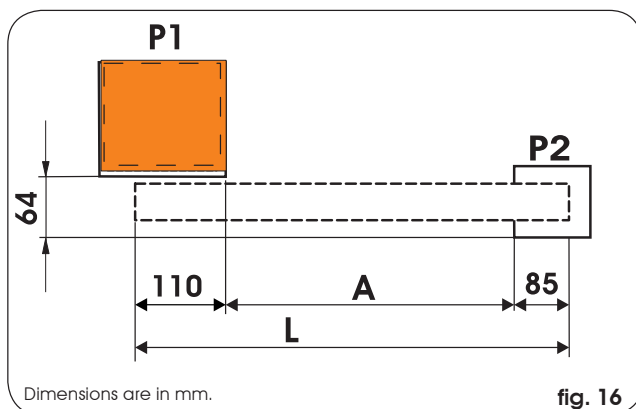

fig. 16

To position the foundation plate of the fork support, refer to fig.16 where:

- P1 = barrier foundation plate
- P2 = fork support foundation plate
- L = beam length (in mm)
- A = L - 195 (in mm)

ARTICULATION KIT (fig.17)

The articulation kit makes it possible to articulate a rigid beam to a maximum ceiling height of 3 m. (see specific instructions).

⚠ If the articulated kit is installed, the balancing spring must be adapted.

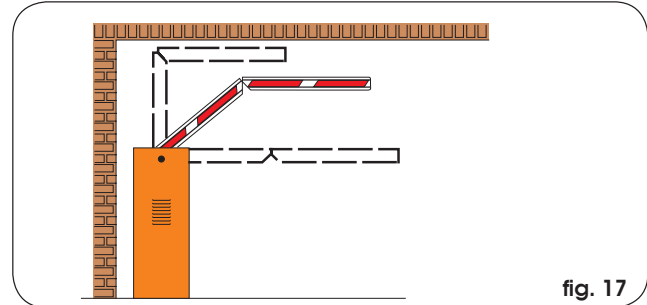

fig. 17

END FOOT (fig.18)

The end foot allows the beam to rest when closed and thus prevents the profile bending downward.

⚠ If a foot is installed, the balancing spring must be readjusted.

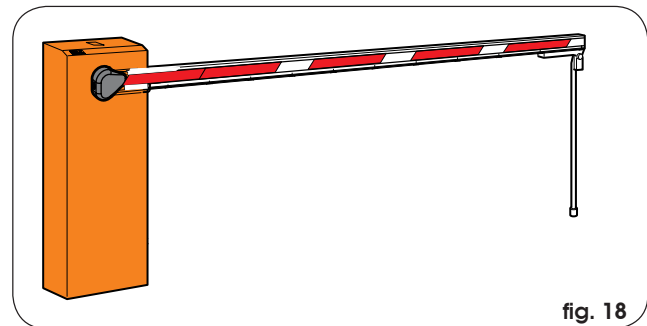

fig. 18

10 MAINTENANCE

Whenever doing maintenance, always check correct settings of the by-pass screws, system balancing, and efficiency of safety devices. The automated system does not require any type of oil topping-up.

11 REPAIRS

For any repairs, contact FAAC's authorised Repair Centres.

Le descrizioni e le illustrazioni del presente manuale non sono impegnative. La FAAC si riserva il diritto, lasciando inalterate le caratteristiche essenziali dell'apparecchiatura, di apportare in qualunque momento e senza impegnarsi ad aggiornare la presente pubblicazione, le modifiche che essa ritiene convenienti per miglioramenti tecnici o per qualsiasi altra esigenza di carattere costruttivo o commerciale.

The descriptions and illustrations contained in the present manual are not binding. FAAC reserves the right, whilst leaving the main features of the equipments unaltered, to undertake any modifications it holds necessary for either technical or commercial reasons, at any time and without revising the present publication.

Les descriptions et les illustrations du présent manuel sont fournies à titre indicatif. FAAC se réserve le droit d'apporter à tout moment les modifications qu'elle jugera utiles sur ce produit tout en conservant les caractéristiques essentielles, sans devoir pour autant mettre à jour cette publication.

Die Beschreibungen und Abbildungen in vorliegendem Handbuch sind unverbindlich. FAAC behält sich das Recht vor, ohne die wesentlichen Eigenschaften dieses Gerätes zu verändern und ohne Verbindlichkeiten in Bezug auf die Neufassung der vorliegenden Anleitungen, technisch bzw. konstruktiv/kommerziell bedingte Verbesserungen vorzunehmen.

Las descripciones y las ilustraciones de este manual no comportan compromiso alguno. FAAC se reserva el derecho, dejando inmutadas las características esenciales de los aparatos, de aportar, en cualquier momento y sin comprometerse a poner al día la presente publicación, todas las modificaciones que considere oportunas para el perfeccionamiento técnico o para cualquier otro tipo de exigencia de carácter constructivo o comercial.

De beschrijvingen in deze handleiding zijn niet bindend. FAAC behoudt zich het recht voor op elk willekeurig moment de veranderingen aan te brengen die het bedrijf nuttig acht met het oog op technische verbeteringen of alle mogelijke andere productie- of commerciële eisen, waarbij de fundamentele eigenschappen van de apparaat gehandhaafd blijven, zonder zich daardoor te verplichten deze publicatie bij te werken.

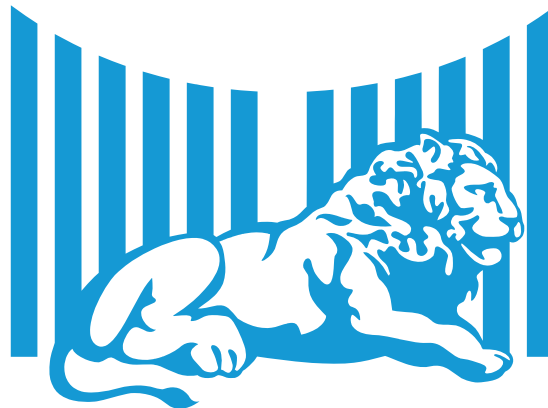

FAAC

FAAC S.p.A.
Via Calari, 10
40069 Zola Predosa (BO) - ITALIA
Tel. 0039.051.61724 - Fax. 0039.051.758518
www.faac.it
www.faacgroup.com



732387 - Rev. E